

TECHNICAL REPORT

INTERNATIONAL SPECIAL COMMITTEE ON RADIO INTERFERENCE

**Radio interference characteristics of overhead power lines and high-voltage equipment –
Part 2: Methods of measurement and procedure for determining limits**





THIS PUBLICATION IS COPYRIGHT PROTECTED

Copyright © 2010 IEC, Geneva, Switzerland

All rights reserved. Unless otherwise specified, no part of this publication may be reproduced or utilized in any form or by any means, electronic or mechanical, including photocopying and microfilm, without permission in writing from either IEC or IEC's member National Committee in the country of the requester.

If you have any questions about IEC copyright or have an enquiry about obtaining additional rights to this publication, please contact the address below or your local IEC member National Committee for further information.

IEC Central Office
3, rue de Varembe
CH-1211 Geneva 20
Switzerland
Email: inmail@iec.ch
Web: www.iec.ch

About the IEC

The International Electrotechnical Commission (IEC) is the leading global organization that prepares and publishes International Standards for all electrical, electronic and related technologies.

About IEC publications

The technical content of IEC publications is kept under constant review by the IEC. Please make sure that you have the latest edition, a corrigenda or an amendment might have been published.

- Catalogue of IEC publications: www.iec.ch/searchpub

The IEC on-line Catalogue enables you to search by a variety of criteria (reference number, text, technical committee,...). It also gives information on projects, withdrawn and replaced publications.

- IEC Just Published: www.iec.ch/online_news/justpub

Stay up to date on all new IEC publications. Just Published details twice a month all new publications released. Available on-line and also by email.

- Electropedia: www.electropedia.org

The world's leading online dictionary of electronic and electrical terms containing more than 20 000 terms and definitions in English and French, with equivalent terms in additional languages. Also known as the International Electrotechnical Vocabulary online.

- Customer Service Centre: www.iec.ch/webstore/custserv

If you wish to give us your feedback on this publication or need further assistance, please visit the Customer Service Centre FAQ or contact us:

Email: csc@iec.ch
Tel.: +41 22 919 02 11
Fax: +41 22 919 03 00



TECHNICAL REPORT

INTERNATIONAL SPECIAL COMMITTEE ON RADIO INTERFERENCE

**Radio interference characteristics of overhead power lines and high-voltage equipment –
Part 2: Methods of measurement and procedure for determining limits**

INTERNATIONAL
ELECTROTECHNICAL
COMMISSION

PRICE CODE **XB**

ICS 33.100.01

ISBN 978-2-88912-017-8

CONTENTS

FOREWORD.....	6
INTRODUCTION.....	8
1 Scope.....	10
2 Normative references.....	10
3 Terms and definitions.....	11
4 Measurements.....	11
4.1 Measuring instruments.....	11
4.1.1 Response of a standard quasi-peak CISPR measuring receiver to a.c. generated corona noise.....	11
4.1.2 Other measuring instruments.....	12
4.2 On-site measurements on HV overhead power lines.....	12
4.2.1 General.....	12
4.2.2 Measurements in the frequency range from 0,15 MHz to 30 MHz.....	12
4.2.3 Measurements in the frequency range from 30 MHz to 300 MHz.....	14
4.3 Statistical evaluation of the radio noise level of a line.....	15
4.4 Additional information to be given in the report.....	16
4.5 Measurements on HV equipment in the laboratory.....	16
4.5.1 Overview.....	16
4.5.2 State of the test object.....	17
4.5.3 Test area.....	17
4.5.4 Atmospheric conditions.....	18
4.5.5 Test circuit – Basic diagram.....	18
4.5.6 Practical arrangement of the test circuit.....	18
4.5.7 Test circuit components.....	19
4.5.8 Measuring receiver connections.....	19
4.5.9 Mounting and arrangement of test object.....	21
4.5.10 Measurement frequency.....	21
4.5.11 Checking of the test circuit.....	21
4.5.12 Calibration of the test circuit.....	21
4.5.13 Test procedure.....	22
4.5.14 Related observations during the test.....	23
4.5.15 Data to be given in test report.....	23
5 Methods for derivation of limits for HV power systems.....	24
5.1 Overview.....	24
5.2 Significance of CISPR limits for power lines.....	24
5.3 Technical considerations for derivation of limits for lines.....	25
5.3.1 Basic approach.....	25
5.3.2 Scope.....	25
5.3.3 Minimum broadcast signal levels to be protected.....	26
5.3.4 Required signal-to-noise ratio.....	27
5.3.5 Use of data on radio noise compiled during measurements in the field.....	28
5.3.6 Use of data obtained by prediction of the radio noise from high-voltage overhead power lines.....	29
5.4 Methods of determining compliance of measured data with limits.....	30
5.4.1 Long-term recording.....	30
5.4.2 Sampling method.....	31

5.4.3	Survey methods.....	31
5.4.4	Alternative criteria for an acceptable noise level.....	31
5.5	Examples for derivation of limits in the frequency range below 30 MHz.....	32
5.5.1	Radio reception.....	32
5.5.2	Television reception, 47 MHz to 230 MHz.....	33
5.6	Additional remarks.....	34
5.7	Technical considerations for derivation of limits for line equipment and HVAC substations.....	34
5.7.1	General.....	34
5.7.2	Current injected by line components and hardware.....	35
5.7.3	Current injected by substation equipment.....	35
5.7.4	Practical derivation of limits in the l.f. and m.f. band.....	35
6	Methods for derivation of limits for the radio noise produced by insulator sets.....	37
6.1	General considerations.....	37
6.2	Insulator types.....	37
6.3	Influence of insulator surface conditions.....	38
6.3.1	General.....	38
6.3.2	Clean insulators.....	38
6.3.3	Slightly polluted insulators.....	38
6.3.4	Polluted insulators.....	39
6.4	Criteria for setting up radio noise limits for insulators.....	39
6.4.1	General.....	39
6.4.2	Criterion for insulators to be installed in type A areas.....	40
6.4.3	Criterion for insulators to be installed in type B areas.....	40
6.4.4	Criterion for insulators to be installed in type C areas.....	40
6.5	Recommendations.....	40
7	Methods for derivation of limits for the radio noise due to HVDC converter stations and similar installations.....	42
7.1	General considerations.....	42
7.2	Sources of interference.....	43
7.2.1	Mechanism of radio noise generation.....	43
7.2.2	Influence of station design on radio interference.....	43
7.3	Radiated fields from valve halls.....	44
7.3.1	Frequency spectra.....	44
7.3.2	Lateral attenuation.....	44
7.3.3	Reduction of the radio interference due to direct radiation from the valve hall.....	44
7.4	Conducted interference along the transmission lines.....	45
7.4.1	Description of the mechanism and typical longitudinal profiles.....	45
7.4.2	Reduction of the interference conducted along the transmission lines.....	45
7.5	General criteria for stating limits.....	46
7.5.1	Overview.....	46
7.5.2	Direct radiation.....	46
7.5.3	Propagation along the lines.....	46
8	Figures.....	48
	Annex A (informative) Radio interference measuring apparatus differing from the CISPR basic standard instruments.....	62
	Annex B (normative) List of additional information to be included in the report on the results of measurements on operational lines.....	63

Annex C (informative) Minimum broadcast signal levels to be protected – ITU recommendations	64
Annex D (informative) Minimum broadcast signals to be protected – North American standards.....	65
Annex E (informative) Required signal-to-noise ratios for satisfactory reception.....	66
Annex F (informative) Derivation of the formula for the protected distance.....	69
Bibliography.....	70
Figure 1 – Transformation of pulses through a CISPR measuring receiver	48
Figure 2 – Bursts of corona pulses generated by alternating voltage.....	49
Figure 3 – Example of extrapolation to determine the radio noise field strength reference level of a power line, here at the direct reference distance of 20 m	49
Figure 4 – Basic test circuit.....	50
Figure 5 – Standard test circuit.....	50
Figure 6 – Connection to the measuring receiver by a coaxial cable	51
Figure 7 – Connection to the measuring receiver by a balanced cable	51
Figure 8 – Special test circuit.....	51
Figure 9 – Arrangement for calibration of the standard test circuit.....	52
Figure 10 – Map showing boundaries of zones A, B, and C in regions 1 and 3	53
Figure 11 – Illustration of the four basic parameters for a power transmission line	54
Figure 12 – Example of typical statistical yearly "all-weather" distributions of the radio-noise levels of a bipolar direct current line (-----) and for an alternating current line in a moderate climate (- - -)	55
Figure 13 – Example of radio noise voltage level V , as a function of the relative air humidity R.H., in clean conditions and slightly polluted conditions, of a standard insulator (—) and a particular type of "low noise" insulator (- - -)	56
Figure 14 – Example of frequency spectra of pulses with different rise times, simulating commutation phenomena in mercury valves and in thyristor valves	56
Figure 15 – Example of frequency spectra of the radio interference recorded outside the hall of a mercury arc valve converter station with and without toroidal filters	57
Figure 16 – Example of frequency spectra of the radio interference recorded outside the hall of a thyristor valve converter station for different operating conditions.....	57
Figure 17 – Attenuation of the field strength as a function of the distance on a horizontal plane, for different frequencies	58
Figure 18 – Example of frequency spectrum of the radio interference in the vicinity of a d.c. line (30 m) at a short distance from the converter station	59
Figure 19 – Example of frequency spectrum of the radio interference in the vicinity of an a.c. line (20 m) at a short distance from the converter station	60
Figure 20 – Frequency spectra of radio interference at 20 m from the electrode line at 1,5 km from the Gotland HVDC link in Sweden with mercury arc groups or thyristor groups in operation.....	60
Figure 21 – Frequency spectra of radio interference at 20 m from the electrode line at 1,5 km and 4,5 km from the Gotland HVDC link in Sweden with mercury arc groups in operation	61
Figure 22 – Frequency spectra of the radio interference recorded along a 200 kV d.c. line, at 20 m from the conductor, at different distances from the converter station	61
Table 1 – Number of n sets of measurement of the radio noise level and corresponding values for factor k	16

Table 2 – Minimum usable broadcast signal field strengths in the v.h.f bands according to CCIR	27
Table 3 – Recommendations for the radio noise voltage limits and for the test methods for insulator sets installed in different areas	42
Table C.1 – Minimum field strength	64
Table C.2 – Nominal usable field strength	64
Table D.1 – Signal levels at the edge of the service area in North America	65
Table E.1 – Summary of signal-to-noise ratios for corona from a.c. lines (Signal measured with average detector, noise measured with quasi-peak detector)	66
Table E.2 – Quality of radio reception or degree of annoyance due to RFI	67

INTERNATIONAL ELECTROTECHNICAL COMMISSION
INTERNATIONAL SPECIAL COMMITTEE ON RADIO INTERFERENCE

**RADIO INTERFERENCE CHARACTERISTICS
OF OVERHEAD POWER LINES
AND HIGH-VOLTAGE EQUIPMENT –**

**Part 2: Methods of measurement
and procedure for determining limits**

FOREWORD

- 1) The International Electrotechnical Commission (IEC) is a worldwide organization for standardization comprising all national electrotechnical committees (IEC National Committees). The object of IEC is to promote international co-operation on all questions concerning standardization in the electrical and electronic fields. To this end and in addition to other activities, IEC publishes International Standards, Technical Specifications, Technical Reports, Publicly Available Specifications (PAS) and Guides (hereafter referred to as "IEC Publication(s)"). Their preparation is entrusted to technical committees; any IEC National Committee interested in the subject dealt with may participate in this preparatory work. International, governmental and non-governmental organizations liaising with the IEC also participate in this preparation. IEC collaborates closely with the International Organization for Standardization (ISO) in accordance with conditions determined by agreement between the two organizations.
- 2) The formal decisions or agreements of IEC on technical matters express, as nearly as possible, an international consensus of opinion on the relevant subjects since each technical committee has representation from all interested IEC National Committees.
- 3) IEC Publications have the form of recommendations for international use and are accepted by IEC National Committees in that sense. While all reasonable efforts are made to ensure that the technical content of IEC Publications is accurate, IEC cannot be held responsible for the way in which they are used or for any misinterpretation by any end user.
- 4) In order to promote international uniformity, IEC National Committees undertake to apply IEC Publications transparently to the maximum extent possible in their national and regional publications. Any divergence between any IEC Publication and the corresponding national or regional publication shall be clearly indicated in the latter.
- 5) IEC itself does not provide any attestation of conformity. Independent certification bodies provide conformity assessment services and, in some areas, access to IEC marks of conformity. IEC is not responsible for any services carried out by independent certification bodies.
- 6) All users should ensure that they have the latest edition of this publication.
- 7) No liability shall attach to IEC or its directors, employees, servants or agents including individual experts and members of its technical committees and IEC National Committees for any personal injury, property damage or other damage of any nature whatsoever, whether direct or indirect, or for costs (including legal fees) and expenses arising out of the publication, use of, or reliance upon, this IEC Publication or any other IEC Publications.
- 8) Attention is drawn to the Normative references cited in this publication. Use of the referenced publications is indispensable for the correct application of this publication.
- 9) Attention is drawn to the possibility that some of the elements of this IEC Publication may be the subject of patent rights. IEC shall not be held responsible for identifying any or all such patent rights.

The main task of IEC technical committees is to prepare International Standards. However, a technical committee may propose the publication of a technical report when it has collected data of a different kind from that which is normally published as an International Standard, for example "state of the art".

CISPR 18-2, which is a technical report, has been prepared by CISPR subcommittee B: Interference relating to industrial, scientific and medical radio-frequency apparatus, to other (heavy) industrial equipment, to overhead power lines, to high voltage equipment and to electric traction.

This second edition cancels and replaces the first edition published in 1986. It is a technical revision.

This edition includes the following significant technical changes with respect to the previous edition: while the first edition of CISPR 18-2 only considered the direct distance D_0 for the establishment of standard profiles for the lateral radio noise field emanating from HV overhead power lines, this second edition now also allows for use of the lateral distance y_0 for these purposes. This way it allows for conduction of on-site measurements and simplified recording and use of measurement data obtained at lateral distances y slant to the pathway of modern HV and UHV overhead power line constructions with tall suspension towers.

The text of this technical report is based on the following documents:

DTR	Report on voting
CISPR/B/494/DTR	CISPR/B/502/RVC

Full information on the voting for the approval of this technical report can be found in the report on voting indicated in the above table.

This technical report has been drafted in accordance with the ISO/IEC Directives, Part 2.

A list of all parts of the CISPR 18 series can be found, under the general title *Radio interference characteristics of overhead power lines and high-voltage equipment*, on the IEC website.

The committee has decided that the contents of this publication will remain unchanged until the stability date indicated on the IEC web site under "<http://webstore.iec.ch>" in the data related to the specific publication. At this date, the publication will be

- reconfirmed,
- withdrawn,
- replaced by a revised edition, or
- amended.

A bilingual version of this publication may be issued at a later date.

INTRODUCTION

This technical report forms the second of a three-part publication dealing with radio noise generated by electrical power transmission and distribution facilities (overhead lines and substations). It contains recommendations for conduction of on-site measurements of electromagnetic noise fields in the vicinity of high-voltage (HV) overhead power lines and substations and for determination of limits for protection of radio reception.

The recommendations given in this part 2 of the CISPR 18 series are intended to be a useful aid to engineers involved in maintenance of overhead lines and substations and also to anyone concerned with checking the radio noise performance of a line to ensure satisfactory protection of radio reception. Information on the physical phenomena involved in the generation of electromagnetic noise fields is found in CISPR/TR 18-1. It also includes the main properties of such fields and their numerical values. CISPR/TR 18-3 eventually contains a Code of Practice for minimizing the generation of radio noise.

This second edition of CISPR/TR 18-2 was adapted to the modern structure and content of technical reports issued by IEC. The first edition of CISPR 18-2 underwent thorough edition and adaptation to modern terminology. Furthermore its content was adjusted such as to allow for use of the lateral distance y for the conduction of measurements in the field.

The CISPR 18 series does not deal with biological effects on living matter or any issues related to exposure in electromagnetic fields.

The main content of this technical report is based on historical CISPR Rec. No. 56 given below:

RECOMMENDATION No. 56

METHODS OF MEASUREMENT OF RADIO INTERFERENCE CAUSED BY OVERHEAD POWER LINES AND HIGH-VOLTAGE EQUIPMENT AND THE PROCEDURE FOR DETERMINING LIMITS

The CISPR

CONSIDERING

- a) that a general description of the radio interference characteristics of overhead power lines and high-voltage equipment has been published in CISPR 18-1,
- b) that the methods of measurement of these characteristics need to be established,
- c) that national authorities require guidance on the procedure for determining limits of such radio interference.

RECOMMENDS

That the latest edition of CISPR/TR 18-2, including amendments, be used for methods of measurement of radio interference characteristics of overhead power lines and high-voltage equipment and for procedures for determining limits.

CISPR/TR 18-1 describes the main properties of the physical phenomena involved in the production of disturbing electromagnetic fields by overhead lines and provides numerical values of such fields.

In CISPR/TR 18-2 methods of measurement and procedures for determining limits of such radio interference are recommended.

The methods of measurement in CISPR/TR 18-2 detail the techniques and procedures for use when measuring fields on site near to an overhead line and also the techniques and procedures for making laboratory measurements of interference voltages and currents generated by line equipment and accessories.

The procedures for determining limits define the expected values of radio noise field and the width of the "disturbed" corridor following the route of the line.

This corridor takes into account the effective field strength of the wanted signal, the signal-to-noise ratio selected and the expected strength of the noise field for a given line.

The procedures are only valid for long and medium waves as the procedures applicable to VHF frequency-modulation broadcasting have not yet been decided, due to insufficient knowledge.

It is emphasized that this part of CISPR 18 does not specify a single set of limits to be applied internationally. Rather it details the procedures to enable national authorities to specify limits where it is decided there is a need for regulations.

RADIO INTERFERENCE CHARACTERISTICS OF OVERHEAD POWER LINES AND HIGH-VOLTAGE EQUIPMENT –

Part 2: Methods of measurement and procedure for determining limits

1 Scope

This part of CISPR 18, which is a technical report, applies to radio noise from overhead power lines and high-voltage equipment which may cause interference to radio reception.

The frequency range covered is 0,15 MHz to 300 MHz.

A general procedure for establishing the limits of the radio noise field from the power lines and equipment is recommended, together with typical values as examples, and methods of measurement.

The clause on limits concentrates on the low frequency and medium frequency bands and it is only in these bands where ample evidence, based on established practice, is available. No examples of limits to protect radio reception in the frequency band 30 MHz to 300 MHz have been given, as measuring methods and certain other aspects of the problems in this band have not yet been fully resolved. Site measurements and service experience have shown that levels of noise from power lines at frequencies higher than 300 MHz are so low that interference is unlikely to be caused to television reception.

The values of limits given as examples are calculated to provide a reasonable degree of protection to the reception of broadcasting at the boundary of the recognized service areas of the appropriate transmitters in the radio frequency bands used for a.m. broadcasting, in the least favourable conditions likely to be generally encountered. These limits are intended to provide guidance at the planning stage of the line and national standards or other specifications against which the performance of the line may be checked after construction and during its useful life.

The measuring apparatus and methods used for checking compliance with limits should comply with the respective CISPR specifications, as e.g. the basic standards series CISPR 16, see [1]*.

2 Normative references

The following referenced documents are indispensable for the application of this document. For dated references, only the edition cited applies. For undated references, the latest edition of the referenced document (including any amendments) applies.

IEC 60050-161, *International Electrotechnical Vocabulary (IEV) – Chapter 161: Electromagnetic compatibility*

IEC 60060-2, *High-voltage test techniques – Part 2: Measuring systems*

* The figures in square brackets refer to the Bibliography.

CISPR 16-1-1, *Specification for radio disturbance and immunity measuring apparatus and methods – Part 1-1: Radio disturbance and immunity measuring apparatus – Measuring apparatus*

CISPR 16-4-3, *Specification for radio disturbance and immunity measuring apparatus and methods – Part 4-3: Uncertainties, statistics and limit modelling – Statistical considerations in the determination of EMC compliance of mass-produced products*

CISPR/TR 18-1:2010, *Radio interference characteristics of overhead power lines and high-voltage equipment – Part 1: Description of phenomena*

CISPR/TR 18-3:2010, *Radio interference characteristics of overhead power lines and high-voltage equipment – Part 3: Code of practice for minimizing the generation of radio noise*

ISO/IEC Guide 99, *International vocabulary of metrology – Basic and general concepts and associated terms (VIM)*

NOTE Informative references are listed in the Bibliography.

3 Terms and definitions

For the purposes of this document, the terms and definitions given in the IEC 60050-161 and the ISO/IEC Guide 99 apply.

4 Measurements

4.1 Measuring instruments

4.1.1 Response of a standard quasi-peak CISPR measuring receiver to a.c. generated corona noise

CISPR 16-1-1 specifies the response characteristic of a measuring receiver to periodically repeated pulses, according to their repetition frequency, for a number of different frequency ranges and bandwidths including the range 0,15 MHz to 30 MHz and a resolution bandwidth of 9 kHz.

Figure 1 indicates the form these pulses take as they progress through the various stages of the measuring receiver. However, in the special case of corona pulses generated by high-voltage a.c. power systems, the individual pulses are not equally spaced throughout a cycle but occur in closely packed groups or bursts around the peak of the voltage waveform. A burst has a duration not exceeding 2 ms to 3 ms and this is followed by a quiescent no-corona period.

Owing to its inherent time constants, a standard quasi-peak CISPR measuring receiver is unable to respond to individual pulses within a burst, which is seen as a single pulse whose amplitude is discussed below.

Hence, the pulse repetition frequency, in the meaning of the CISPR definition is constant at $2f$ (where f is the power system frequency) for single phase and $6f$ for three-phase single or multi-circuit systems, provided that the individual circuits are part of the same system.

Figure 2 indicates the usual case where individual corona pulses generated around the positive peaks of the voltage waveform are much greater in amplitude than those generated around the negative peaks. Hence in a three-phase power line there are three bursts of higher amplitude and three burst of lower amplitude noise during each period of $1/f$.

Also, in the measurement of the radio noise field strength in close vicinity of an operational line, the antenna of the measuring receiver is not located at the same distance from all the phase conductors. Then because a quasi-peak detector responds only to the higher amplitude bursts and disregards the lower ones, rules of summation of the radio noise generated by the individual phases of a line can be formulated which are specific to the CISPR characteristics and are given in Clause 4 of CISPR/TR 18-3. It should be noted that the loudspeaker of a radio receiver, and consequently the listener, perceives the overall generated noise.

To examine the response of the CISPR measuring receiver to a given burst of pulses, it should be borne in mind that each individual pulse becomes, at the output of the amplifier of figure 1 of pass-band Δf , a damped oscillation whose duration can be taken as approximately $2/\text{RBW}$ (i.e. 0,5 times its IF amplifier resolution bandwidth), or 0,22 ms for 9 kHz. When there are a large number of pulses distributed at random within a burst, the resulting oscillations will overlap randomly and the overall quasi-peak signal will be approximately equal to the quadratic sum of the individual quasi-peak values. This statement, which is difficult to prove mathematically, has been well proven by experience and justifies the use, in quasi-peak detection, of the quadratic summation law which would moreover be rigorous if the noise levels were expressed in r.m.s. values.

4.1.2 Other measuring instruments

Measuring instruments differing from standard CISPR instruments are referred to in Annex A although measuring instruments having detectors other than quasi-peak are also referred to in CISPR 16-1-1.

4.2 On-site measurements on HV overhead power lines

4.2.1 General

On-site measurements in the vicinity of HV overhead power lines should be carried out in accordance with the instructions given in this clause. Further information about a possible assessment and documentation of measured data is found in 5.3.5 and 5.4.

4.2.2 Measurements in the frequency range from 0,15 MHz to 30 MHz

4.2.2.1 Reference frequency

The reference measurement frequency is 0,5 MHz. It is recommended that measurements are made at a frequency of $0,5 \text{ MHz} \pm 10 \%$ but other frequencies, for example 1 MHz, may also be used. The frequency of 0,5 MHz (or 1 MHz) is preferred because, usually, the level of radio noise at this part of the spectrum is representative of the higher levels and also because 0,5 MHz lies between the low and medium frequency broadcast bands.

Because of the possibility of error due to the presence of standing waves, it is inadvisable to rely on the measured value of the radio noise field strength at a single frequency but to draw a mean curve through the results of a number of readings throughout the noise spectrum. Measurements should be made at, or near, the following frequencies: 0,15 MHz, 0,25 MHz, 0,5 MHz, 1,0 MHz, 1,5 MHz, 3,0 MHz, 6,0 MHz, 10,15 MHz and 30 MHz although, clearly, frequencies at which interference to the wanted noise is received, should be avoided.

4.2.2.2 Measurement antenna

The antenna used for the measurements shall be an electrically-screened vertical loop, whose dimensions are such that the antenna will be completely enclosed by a square having a side of 600 mm in length. The balance shall be such that in a uniform field the ratio between the maximum and minimum indications on the measuring receiver when the antenna is rotated shall not be less than 20 dB. The base of the loop should be about 2 m above ground. The antenna shall be rotated around a vertical axis and the maximum indication noted. If the plane of the loop is not effectively parallel to the direction of the power line, the orientation should be stated.

NOTE According to the ANSI/IEEE Standard 430 (1986) [4], the antenna height using measurement vehicle is recommended as below:

If a vehicle-mounted antenna is used, the antenna should be at least 2 m above the roof of the vehicle. The effects of vehicles on vehicle-mounted antennas have been found to be negligible if this minimum height of 2 m is maintained; however, the vehicle and antenna combination should be calibrated to confirm the antenna factors and to check for existence of azimuthal asymmetries in the antenna pattern, as described in Section 5 of IEEE Standard 473 (1985) [5].

A check shall be made to ensure that the supply mains, if used, or other conductors connected to the measuring apparatus do not affect the measurements.

4.2.2.3 Selection of measurement points along the pathway of the overhead HV power transmission line

To determine the radio noise performance of a line certain positions of measurement should be avoided; but these restrictions would not apply when an investigation into a case of interference is being carried out.

Measurements should be made at mid-span between the towers and preferably at several such positions. Measurements should not be made near points where lines change direction or intersect.

Sites at an abnormal height of span should be avoided. The measuring site should be flat, free from trees and bushes and remote from large metal structures and other overhead power and telephone lines.

Ideally the measuring site should be at a distance greater than 10 km from a line termination, in order to avoid reflection effects and consequently inaccurate results, but lower voltage distribution lines are sometimes too short to enable this condition to be met. However, the results of measurement (see reference [6]) indicate that the level of the radio noise field strength in the absence of reflections corresponds to the geometric mean of the maximum and minimum values, in microvolt per metre ($\mu\text{V/m}$), of the frequency spectrum from a line subjected to reflections.

If the line is transposed, the measuring site should be located as far as possible from the transposition towers.

The atmospheric conditions should be approximately uniform along the line. Measurements under rain conditions will be valid only if the rain extends over at least 10 km of the line on either side of the measuring site.

Annex B gives a list of such information.

4.2.2.4 Selection of measurement points lateral to the pathway of the overhead HV power transmission line

Measurements are performed e.g. for determination of the lateral field strength profile of the radio noise field generated by overhead HV power transmission lines. In these conditions a number of measurement points at mid-span in between two towers should be chosen along a straight line departing perpendicular from the pathway of the overhead HV power transmission line under test. The distances of measurement shall be taken laterally from the vertical projection to ground of the outmost sub-conductor of the transmission line (reference point (x,y,z) , i.e. x = place along the line at mid-span where the measurements are made, $y = 0$ m and $z = 0$ m corresponding to the vertical projection to ground of the outmost sub-conductor) to the centre of the antenna used for the measurements. For determination of the overall typical lateral field strength profile of the radio noise field of a given overhead HV power transmission line it may be sufficient to consider lateral distances y in the range from 0 m to 200 m.

In order to allow for comparison of measured lateral profiles of the radio noise fields generated by several individual HV power transmission lines of the same type or by several HV power transmission lines of different types it is necessary to determine a reference distance at which the observed profile curves converge through the same indication level. Practice proved that this is the case for a distance of 15 m taken laterally from the vertical projection to ground of the outmost sub-conductor (i.e. the reference point) of the transmission line concerned. That is why this 15 m distance is defined as the lateral reference distance y_0 for comparison of different lateral profiles.

In order to allow for subsequent comparison with other lateral radio noise field profiles, normalised profiles should either be related directly to that lateral reference distance of 15 m or, in case that measurements could not be performed at that distance, the obtained results should be normalised to the reference distance by means of the interpolation described in the next paragraph.

NOTE 1 In case of most of already operated conventional overhead HV power transmission lines the normalised versions of lateral profiles of the radio noise fields obtained in a direct distance of 20 m from the nearest conductor converge through the same indication level as those obtained in the new lateral reference distance of 15 m, due to the usual height of the conductors above ground. It should however be kept in mind that the direct distance of 20 m used so far may prove impractical for prediction of the radio noise for transmission lines utilising higher voltages and for which high towers may be used. In order to allow for measurements at ground level also in these conditions the CISPR reference distance of 20 m taken directly from the nearest sub-conductor of the line was changed to a lateral distance of 15 m, see explanation above.

When the obtained profile of the radio noise field is plotted as a function of the distance using a logarithmic scale, a substantially straight line is obtained. Under these conditions, the field at 20 m (direct distance) or simultaneously 15 m (lateral distance) is readily obtained by interpolation or extrapolation (see Figure 3).

The height of the axis of the lowest phase bundle of sub-conductors above ground should be measured at mid-span and recorded in the test report.

NOTE 2 Regarding the prediction formula covered in CISPR/TR 18-3 care should be taken when calculating the emissions since it still refers to the direct distance.

4.2.3 Measurements in the frequency range from 30 MHz to 300 MHz

4.2.3.1 Reference frequency

Because the frequency bands dedicated to television broadcasting vary in the countries around the world, a single reference measurement frequency for noise in television broadcast frequency bands cannot be fixed as like noise in the a.m. sound broadcasting frequency ranges. However it is recommended that measurements are made at a frequency of 75 MHz but other frequencies, for example 150 MHz, may also be used. These frequencies should be selected since the noise strongly affects the video signal of broadcasting in the lower v.h.f. bands. The frequency of 75 MHz (or 150 MHz) belong to these low v.h.f. broadcasting frequency bands.

4.2.3.2 Measurement antenna

The antenna used for the measurements shall be a passive antenna, for example a biconical antenna. Under the transmission line, strong electric induction effects from the power-frequency voltage can provoke a malfunction of an active antenna. The biconical antenna should be allocated about 3 m above ground. The antenna is to be rotated around a horizontal axis and the maximum indication noted. Generally the plane of the biconical antenna is not perpendicular to the direction of the power line, it tilts about 5° or 10° to the perpendicular direction of the power line.

4.2.3.3 Selection of measurement points along the pathway of the overhead HV power transmission line

To determine the noise performance of a line in the v.h.f. frequency range, certain positions of measurement should be avoided; but these restrictions would not apply when an investigation into a case of interference is being carried out.

There is no standing wave phenomena as in the lower frequency range, measurements can be made at any position in the span. Sites at an abnormal height of span should be avoided. The measuring site should be flat, free from trees and bushes and remote from large metal structures and other overhead power and telephone lines.

The results of measurement should be indicated in microvolt per metre ($\mu\text{V}/\text{m}$) or its logarithmic equivalent.

If the line is transposed, the measuring site should be located as far as possible from the transposition towers.

The atmospheric conditions should be approximately uniform along the line. Measurements under rain conditions will be valid only if the rain extends over at least 10 km of the line on either side of the measuring site.

Annex B gives a list of such information.

4.3 Statistical evaluation of the radio noise level of a line

When compliance with limits is required, it may be appropriate to use the statistical method given below. Further information about a possible assessment and documentation of measured data is found in 5.3.5 and 5.4.

CISPR 16-4-3 describes statistical sampling methods for establishing the compliance of mass-produced appliances with CISPR limits. The so-called 80 %/80 % rule is based on the application of statistical techniques that have to give the consumer an 80 % degree of confidence that 80 % of the appliances of a type being investigated are below the specified radio noise limit. The method is based on the non-central *t*-distribution (sampling by variables) and the spirit of the 80 %/80 % CISPR rule is interpreted for overhead lines in that the radio noise level should not exceed the limit for more than 80 % of the time with at least 80 % confidence.

Definitions of readings and sets of measurements:

- 1) A reading is the result of a single measurement of the field strength level in $\text{dB}(\mu\text{V}/\text{m})$, at a given location, under given meteorological conditions. If the meter readings fluctuate, then an average value taken over a period of at least 10 min should be used.
- 2) Each set of measurements consists of averaging the readings taken, for a given meteorological condition, at three different locations approximately evenly distributed along the line. Not more than one set of measurements should be taken on any particular day for the given meteorological conditions. The three different locations will help to eliminate the effects of local irregularities (for example standing waves), although, as stated in 4.2.2.3 and 4.2.2.4, positions of measurement where unrepresentative readings are likely to be obtained should be avoided.

Number of measurements:

- 1) Using the measurement techniques described in 4.2, at least 15 but preferably 20 or more sets of measurements should be taken.
- 2) The number of sets of measurements for each weather condition (dry, rain, snow, etc.) shall be proportional to the frequency of occurrence of each weather condition for the area.

Compliance with a given limit of noise is judged from the following relationship taken from CISPR 16-4-3:

$$\bar{X} + k S_n \leq L$$

where

L is the permissible upper limit of radio noise;

\bar{X} is the mean value of the (n) number of sets of measurements of the radio noise level of the line, namely:

$$\bar{X} = \frac{X_1 + X_2 + \dots + X_i + \dots + X_n}{n}$$

S_n is the standard deviation of the (n) sets of measurements, namely:

$$S_n = \sqrt{\frac{\sum_1^n (X_i - \bar{X})^2}{n - 1}}$$

k is the constant depending on (n) and is determined in such a way that the above stated 80 %/80 % rule is satisfied.

The k value to be used for (n) number of sets of measurements is shown in the table below.

Table 1 – Number of n sets of measurement of the radio noise level and corresponding values for factor k

n	15	20	25	30	35
k	1,17	1,12	1,09	1,07	1,06

This formula, based on a limited number of samples, is similar to that relating to a Gaussian distribution valid for an infinite number of samples, the samples being represented by sets of measurements.

In the formula S_n can be compared with the standard deviation relating to an infinite number of samples and k depends on both the required confidence (80 %/80 %) and on the number of samples. The lower the number of samples the higher the value of k becomes for any percentage specified to meet the limit, with a given confidence.

Studies indicate that even for a non-Gaussian distribution, the use of the above statistical method does not introduce a significant error provided that at least 15 but preferably 20 or more sets of measurements are used in the evaluation.

4.4 Additional information to be given in the report

To ensure that extraneous interference is not influencing the measurement of the levels of the line radio noise field strength it may be necessary to measure the noise levels with the line de-energized.

When the results of the measurements are reported, as much relevant information as possible should be given on the line and on the conditions under which the measurements were carried out.

4.5 Measurements on HV equipment in the laboratory

4.5.1 Overview

This clause gives the method to be used for the measurement, in a laboratory or test area, of radio noise generated by items of plant and components used on high-voltage lines and in

substations, such as circuit-breakers, bushings, insulators and hardware. This method is valid for type tests and for routine or sample tests and also for investigational tests.

It is usual practice to carry out laboratory measurements of radio noise in a prescribed test circuit by measuring conducted quantities (current or voltage) and not the emitted field strength.

Furthermore, the selection of test conditions should be based on the following principle: ideally, the measurements should be made with the conditions and circuit simulating, as far as possible, actual service conditions and, if necessary, the most severe conditions likely to occur for the type of apparatus tested. Before the establishment of a reliable method of radio noise testing in a laboratory, reliance was placed on the voltage at which inception or extinction of visual corona occurred on the test object. The voltages so determined were very dependent on the observer and this method is now being replaced by the laboratory measurements described below.

4.5.2 State of the test object

It is well known that the level of the radio noise produced by high-voltage equipment is very dependent on the state of the surface of the item equipment. In laboratory tests, the state of a particular test object should consequently be clearly defined with regard to the following aspects:

- a) new or already used;
- b) clean or slightly polluted; the nature of the pollution should be specified;
- c) dry, slightly damp, or wet (for example artificial rain conditions);
- d) combination of these states, for example polluted and damp.

Generally, standards and normal practice are restricted to laboratory tests on clean and dry objects, reproducibility of the other test conditions (dampness, pollution) being often difficult to achieve. However, tests on objects submitted to (standardized) rain conditions may be very useful, since these conditions occur frequently in practice and may lead to significantly higher radio noise levels than dry conditions.

When only one surface condition is taken into consideration, it is desirable, in order to be as close as possible to the practical conditions, that the tests be performed on adequately polluted and wet samples, at the normal operating voltage.

When the object is to be tested in a clean and dry state, it may be wiped with a dry cloth to remove dust and fibres that might affect the surface.

Unless otherwise stated, test conditions described in this clause are valid for used, wet and/or polluted objects as well as for new, clean and dry objects.

4.5.3 Test area

The tests should preferably be performed inside a screened room which is large enough to prevent the walls and the floor from having any significant effect on the distribution of the electric field at the surface of the test objects. Circuits, for example power and lighting, entering the screened test area should, ideally, be filtered so as to avoid the introduction of radio noise present in the environment (see 4.5.11).

If a screened room is available, the tests may be carried out at any place where the background noise level is sufficiently low compared with the levels to be measured (see 4.5.11).

4.5.4 Atmospheric conditions

The normal reference atmosphere for tests described herein is:

- temperature: 20 °C;
- pressure: $1,013 \times 10^5$ N/m² (1 013 mbar);
- relative humidity: 65%.

However these tests may also be performed under the following atmospheric conditions:

- temperature: between 15 °C and 35 °C;
- pressure: between $0,870 \times 10^5$ N/m² and $1,070 \times 10^5$ N/m² (870 mbar and 1 070 mbar);
- relative humidity (for tests on objects in the dry state): 45 % to 75 %.

In the case of investigational tests, other conditions may be selected according to the test objective.

When tests are made on a dry object, it shall be in thermal equilibrium with the test area atmosphere to avoid any condensation on the surface of the object.

As far as the radio noise levels generated by a test object are concerned, the effects of changes in atmospheric conditions, within the above limits, from the normal reference conditions are little known. Thus no correction shall be applied to the measured results but the air temperature, air pressure and relative humidity obtaining during the tests shall be recorded.

4.5.5 Test circuit – Basic diagram

Figure 4 shows the principle of the test circuit. The radio-frequency currents generated by the test object flow through that part of the circuit shown by heavy lines which include impedance Z_s and resistance R_L . The radio-frequency rejection filter F virtually prevents these currents from flowing in the high-voltage connections to the transformer and, conversely, any interference currents from other sources present in this high-voltage connection are attenuated by the filter before entering the high frequency part of the circuit. Ideally the impedance of Z_s should be zero at the measurement frequency and infinite at the power supply frequency. Also if R_L represents the resistive load of the test object in service, for example the characteristic impedance of a high voltage line, the radio noise voltage which the test object would inject onto a line conductor or substation connection may be measured across R_L .

CISPR 16-1-2 [2] specifies a value of 300 Ω for R_L and in a practical test circuit (see Figure 5), R_L is the equivalent resistance of R_2 in series with the parallel combination of R_1 and the input resistance of the measuring receiver, R_m .

The test consists of taking measurements, expressed in μ V (or in dB(μ V)) of the pulse-type voltages appearing across a fraction of R_L when a given power-frequency voltage is applied to the object under test.

4.5.6 Practical arrangement of the test circuit

Figure 5 shows the standard test circuit which should be used for the laboratory measurement of the radio noise voltages generated by medium and/or high voltage equipment. The connections to the measuring receiver are shown in a simplified form in Figure 5 and, depending on the distance between the measuring receiver and test circuit, the arrangement shown in either Figure 6 or Figure 7 is incorporated into the circuit of Figure 5.

NOTE In the special, limited, case of the need for rapid comparative measurements to be made on a number of identical small objects, such as cap and pin insulator units for overhead lines, the special test circuit of Figure 8 may be used. The decoupling capacitor C_m may be omitted when the number of test objects exceeds five.

The impedance Z_s is the basic circuit of Figure 4 can consist of i) a series circuit L_2C_2 or ii) simply a capacitor C_3 , as shown in Figure 5.

- i) L_2C_2 is tuned to the measurement frequency along with L_1 in parallel with C_1 , forming the rejection filter F. The advantage of this arrangement is that C_2 may have a relatively low value of capacitance, say 50 pF to 100 pF and therefore be cheaper, but the disadvantage is that measurements at frequencies other than the reference frequency involve the retuning of L_2C_2 and $L_1 C_1$.
- ii) As stated in item d) of 4.5.7, a value of 1 000 pF for C_3 should be satisfactory, which makes an inductor in series with C_3 unnecessary and this part of the test circuit aperiodic. By making the rejection filter F also aperiodic by using, for example, an inductor damped by parallel resistors, measurements at frequencies other than the reference frequency can be carried out relatively simply. If, however, the laboratory or test area is near to industrial premises where high levels of radio noise can be produced, a very high filter impedance is usually required (see item c) of 4.5.7).

4.5.7 Test circuit components

The components that are used in the test circuit shall meet the following requirements.

a) High-voltage connections

The radio noise level produced by the high-voltage connections and terminations of the test circuit shall be insignificant compared with the values to be measured from the test object at the test voltage.

b) High-voltage transformer T_1

This transformer shall provide a voltage waveform consistent with the specifications of IEC 60060-2.

c) Rejection filter

Filter F shall have an impedance of not less than 20 000 Ω , corresponding to an attenuation of at least 35 dB, in either direction at the measurement frequency.

To be fully effective, the filter should be located as near as possible to the high frequency part of the test circuit. When the filter consists of a tuned circuit (L_1C_1), it should be tuned to the measurement frequency by using, for example, a signal generator connected across the secondary terminals of transformer T_1 . Tuning is achieved by varying C_1 to give a minimum reading on the measuring receiver. The filter impedance may be assessed by measuring its insertion loss by taking the difference in the measuring receiver readings with the filter short-circuited and then with the short-circuit removed.

At the reference measurement frequency of 0,5 MHz \pm 10 %, the value of L_1 should be about 200 μ H whereas C_1 should be variable up to a maximum of 600 pF.

d) Measuring impedance

The impedance between the live conductor and earth ($Z_s + R_L$ in Figure 4) shall be (300 \pm 40) Ω with a phase angle not exceeding 20°, at the measurement frequency.

A coupling capacitor C_3 (Figure 5) may be used in place of Z_s provided that the capacitance of C_3 is at least five times greater than the capacitance to earth of the test object and its high voltage connection. In practice, a value of 1 000 pF should be satisfactory for C_3 .

Capacitor C_3 shall be capable of withstanding the maximum test voltage and have a low partial discharge level at that voltage.

4.5.8 Measuring receiver connections

The more usual method of connecting the measuring receiver to the test circuit, that is, where the length of cable is less than about 20 m and co-axial cable is used, is shown in Figure 6. Where the length of cable is greater than 20 m, balanced screened cable is used, and this arrangement is shown in Figure 7.

a) Matching resistor R_1

To reduce the possibility of errors, due to reflections within the connections to the measuring receiver, the co-axial cable, in the case of Figure 6, shall be terminated in its characteristic impedance at each end. Also, in the circuit of Figure 7, the cable/transformer assembly shall be similarly terminated.

The effective input resistance R_m of the measuring receiver usually provides one matching termination and the other termination is provided by R_1 which shall be of the high stability, non-inductive type.

b) Series resistor R_2

To meet the requirement of 300 Ω resistance across the test object, the input resistance R_m of the measuring receiver in parallel with R_1 has to be increased using a series resistor R_2 which shall be of the high stability, non-inductive type. In the case of a measuring receiver where R_m is 50 Ω , the value of R_2 should be 275 Ω .

NOTE 1 In some countries other resistance values are assigned to R_L : for example the National Electrical Manufacturers' Association (NEMA), of the USA, in its Publication 107 (1964) [7], specifies the value of 150 Ω for R_L . Usually a simple conversion can be applied to the results obtained from tests to other specifications. This is because a radio noise source in a test object almost invariably produces a constant current, provided R_L is within the range 100 Ω to 600 Ω and the voltage measured across R_L is simply proportional to its value.

c) Inductor L_3

This inductor provides a low-impedance path at power frequency to divert, from the measuring receiver and its associated components, power frequency currents which flow in C_2 or C_3 . At the reference measurement frequency of 0,5 MHz, L_3 shall have a value of at least 1 mH, with a low self-capacitance, to avoid errors exceeding 1 % or 0,1 dB. For safety reasons, L_3 should be robust and have sturdy and secure electric connections.

d) Spark gap

To reduce the possibility of high voltages appearing on the connections to the measuring receiver, the provision of a protective spark gap across L_3 is recommended. This spark gap should preferably be of the gas-filled type with a maximum breakdown voltage of 500 V on a power frequency sine wave (see note below).

NOTE 2 In the event of a relatively high power frequency voltage appearing across the spark gap, due for example to a failure of the inductor L_3 or its connections, there could be an increase in the test circuit background noise level, because of corona discharges at the electrodes of the spark gap.

e) Balanced cable and balun transformers (T_2 and T_3)

Where the test object is large and/or where very high voltages are involved, the measuring receiver may have to be located at some distance from the base of (C_2, L_2) or C_3 , where R_1 and R_2 are located. Under such conditions the length of co-axial cable shown in Figure 6 may exceed 20 m and, to reduce the possibility of the measurements being affected by interference picked up on this cable, it is recommended that the arrangement shown in Figure 7 should be used.

The balun or coupling transformers T_2 and T_3 should be located close to R_1/R_2 and to the measuring receiver, respectively, and the connection between the transformers should be made by means of a balanced screened cable. Short lengths of co-axial cable should be used to connect T_2 to R_1/R_2 and T_3 to the measuring receiver and all these cables should have suitable characteristic impedances to ensure correct matching.

f) Measuring instrumentation

To comply with CISPR recommendations, the measuring instrumentation shall be consistent with the specifications of CISPR 16-1-1. If a measuring receiver with different characteristics is used, a conversion of the results into values which would have been obtained with a CISPR instrument is usually possible, but this can lead to some inaccuracy. This conversion should be carried out as detailed in 4.1.

4.5.9 Mounting and arrangement of test object

The object under test shall be mounted and arranged in accordance with the requirements of the standard applicable to the particular apparatus concerned (for example, IEC 60437:1997, see [3]). When no such standard is available, the test object shall be arranged, as far as possible, in the same manner and with the same circuit configuration as exist in service.

The object under test shall be provided with all its normal hardware, such as arcing horns and stress-control hardware that may affect the distribution of the electric field at the surface of the test object. Where the test object can be in more than one condition, for example a circuit-breaker which can be open or closed, it shall be tested in each of these conditions.

The high-voltage connections to the object under test shall be short and shall not contribute to the measured values of radio noise from the test object nor influence the distribution of the electric field at its surface.

The coupling impedance, L_2C_2 (or C_3) shall be located near to the test object without significantly disturbing the distribution of the electric field at the surface of the test object.

4.5.10 Measurement frequency

The reference measurement frequency is 0,5 MHz. It is recommended that measurements are made at a frequency of $0,5 \text{ MHz} \pm 10 \%$ but other frequencies, for example 1 MHz, may be used.

4.5.11 Checking of the test circuit

The test circuit shall be arranged so as to permit an accurate measurement of the radio noise level generated by the object under test. Any interference from outside the test circuit, including the supply, or from other parts of the circuit, shall be at a low level and, preferably, at least 10 dB below the level specified for the test object.

With the specified test voltage applied to the circuit, the level of background noise shall be at least 6 dB below the lowest level to be measured. These conditions may be checked by substituting a similar, but noise-free, test object for the object under test.

Background noise levels may be relatively high when the tests are made in an unshielded area, especially when there are industrial premises nearby. When these high levels are of short duration, this condition may be acceptable provided that the quiet periods are of sufficient duration for a reliable measurement to be made and that, during the measurements, the character of the interfering peaks can be clearly distinguished from that of the noise being generated by the test object, possibly by means of an oscilloscope or a loudspeaker.

Interference may also result from broadcast stations which may be overcome by selecting a measurement frequency, within the specific tolerance, which is clear of interference. The use of a resonant circuit L_1C_1 , which is correctly tuned, as the rejection filter F, can often be most effective in reducing background noise.

4.5.12 Calibration of the test circuit

The test circuit shown in Figure 5 together with the circuit shown in either Figure 6 or Figure 7 shall be calibrated to obtain the value of the correction factor that shall be applied to the measuring receiver readings. This factor is the sum of the circuit attenuation and the resistance network factor, both expressed in dB. Such calibration is required where the test assembly is being used for the first time, or has been re-arranged, or where the test object have been changed to one of a significantly different capacitance. The power supply to the high-voltage transformer should be disconnected during calibration.

a) Circuit attenuation A

Before starting the calibration, the rejection filter F shall be tuned, if applicable, as described in item c) of 4.5.7, to the particular measurement frequency. A signal generator with an output impedance of at least 20 000 Ω shall then be connected in parallel with the test object, the test circuit being complete, as shown in Figure 5 together with the circuit shown in either Figure 6 or Figure 7. (Such a generator is easily arranged by connecting a 20 000 Ω resistor in series with the output of a standard signal generator.) The generator shall be set to deliver a sine wave output of 1 V, at the measurement frequency, which will inject a current of about 50 μA into the test circuit. This current will ensure that the level of the reading obtained with a CISPR measuring receiver will be well in excess of the usual background noise level. The level of this reading shall be noted.

With the settings of the generator unchanged, the test object shall be disconnected from the high-voltage part of the test circuit and connected as shown in Figure 9. The level of this new reading shall also be noted and the difference between the two readings is the circuit attenuation A.

NOTE 1 To avoid removing R_1 and R_2 from the test circuit during the calibration procedure, other high-stability, non-inductive resistors of the same value may be used.

NOTE 2 In Figure 9 the test object may be replaced by an equivalent capacitance, if this is known.

b) Resistance network factor

Levels of radio noise voltage generated by the types of apparatus being considered in this clause are usually expressed in dB(μV) across 300 Ω.

Then, if $R_1 = R_m$, the network factor will be as follows:

$$R = 20 \lg \frac{600}{R_1}, \text{ expressed in dB.}$$

The radio noise level of the object being tested is then given by

$$V = V_m + A + R \quad \text{in dB}(\mu\text{V}) \text{ across } 300 \Omega$$

where V_m is the voltage, in dB(μV), indicated by the measuring receiver and corresponding to its input voltage.

NOTE 3 A less complicated alternative method of overall calibration of the test circuit can be carried out in a single operation if a *calibrated* sine-wave current generator is used. This method involves an accurate measurement of both the output voltage V_0 of the signal generator and the value of a 20 000 Ω resistor R_r in series with the generator output. Then when the signal generator, with the 20 000 Ω series resistor, is connected in parallel with the test object a reading V_1 (in μV) appears on the measuring receiver which corresponds to the current i_1 injected into the circuit:

$$i_1 = \frac{V_0}{R_r} \text{ in } \mu\text{A}$$

Under these circumstances, the radio noise level of the apparatus being tested is directly given by:

$$V = V_m = 20 \lg 300 \frac{i_1}{V_1} \quad \text{in dB}(\mu\text{V}) \text{ across } 300 \Omega$$

where V_m is the voltage, in dB(μV), indicated by the measuring receiver at the time of the test.

NOTE 4 The sine-wave signal generator may be replaced by a pulse generator with a constant frequency spectrum, at least up to the measurement frequency. Correspondence of amplitudes between pulse and sinusoidal signals should meet the data included in CISPR 16-1-2 [2].

4.5.13 Test procedure

Radio noise generated by high-voltage equipment depends mainly on the distribution of the electric fields at the surface of the equipment. Ideally, the distribution in service should be reproduced during tests in the laboratory.

The radio noise level generated by a test object is not entirely determined by a particular value of the test voltage. A hysteresis effect often occurs, with the result that noise may or may not be present at a given test voltage, as it depends on whether this voltage was reached by decreasing or increasing values. Pre-conditioning of the test object, by subjecting it to a voltage which is equal to or greater than the specified test voltage for a specific period of time, can also have an effect on the measured level of radio noise.

The procedure for applying the test voltage should therefore be accurately specified.

The test voltage shall be a sine wave at power-supply frequency and be consistent with IEC 60060-2. It shall be applied either:

- a) between phases of the object under test (for example a three-phase circuit-breaker), in which case the test voltage is related to the system's line voltage, or
- b) between phase and earth (for example a complete insulator string), in which case the test voltage is related to the system's phase voltage.

The test voltage of the object to be tested is usually specified in the standard applicable to the type of object. In the absence of such a specification, the test voltage shall be 1,1 times the nominal voltage of the system or the rated voltage of the equipment ($U/\sqrt{3}$ for apparatus tested with respect to earth). In some cases, the test voltage is agreed between manufacturer and purchaser at a value between 1,1 and 1,4 times the nominal voltage of the system or the rated voltage of the equipment.

A voltage 10 % higher than the specified test voltage should be applied to the object under test and maintained for at least 5 min. The voltage should then be decreased in steps to 30 % of the specified test voltage, raised in steps to the initial value, maintained there for 1 minute and, finally, decreased in steps to the 30 % value. Each voltage step should be approximately 10 % of the specified test voltage. At each step a radio noise measurement should be made and the results obtained during the last decreasing run should be plotted against the applied voltage, the curve so obtained being the radio noise characteristic of the test object.

When significant variations are likely to occur in the radio noise level from a number of items of equipment of the same type, the measurements should be done on several samples. Then the typical radio noise characteristic will be the average curve obtained when all the results are taken into account. When the number of samples is sufficient, a level dispersion may also be evaluated. When compliance with limits is required, it may be appropriate to use the statistical method given in CISPR 16-4-3.

4.5.14 Related observations during the test

Additional observations may profitably be carried out at the same time as the radio noise measurements, in order to locate any noise sources on the test object and assist in establishing the cause of possible defects. A visual observation, if necessary by means of binoculars in a darkened laboratory, will enable even extremely small points of corona discharge to be located. Such observations may be confirmed by means of photographs with long exposure times, or by means of an image amplifier. If it is impossible to darken the laboratory sufficiently, the points of discharge may be located to some extent by an ultraviolet detector, by ear or, preferably, by an ultrasonic detector which is much more directional.

4.5.15 Data to be given in test report

In addition to the specification of the apparatus under test, the test report should also give the following data:

- a) state of the test object:
 - 1) new or already used,
 - 2) clean or polluted (nature and degree of pollution),

- 3) dry, damp or wet;
- b) atmospheric conditions:
 - 1) temperature,
 - 2) barometric pressure,
 - 3) relative humidity,
 - 4) presence or absence of rain (standardized artificial rain);
- c) test circuit, including any difference from the standard CISPR circuit;
- d) background noise level;
- e) test voltage with detailed procedure of its application;
- f) measured radio noise levels, expressed in dB(μ V) across 300 Ω (these can be given in the radio noise characteristic);
- g) comparison between the measured levels and any specified limits.

5 Methods for derivation of limits for HV power systems

5.1 Overview

The CISPR has for many years considered the question of limits of radio noise from overhead power lines and high-voltage equipment in order to safeguard audio and video (i.e. television) radio broadcast reception. The degree of annoyance caused by noise in the broadcast radio frequency bands is determined by the signal-to-noise ratio (SNR) at the receiving installation. For similar subjective annoyance, the SNR depends on the nature of the noise source. Based on a required SNR, many factors affect the acceptable level of noise, such as the minimum radio signal level to be protected, minimum distance between power line and receiving location, effects of weather, etc. Further difficulties exist in specifying the conditions for verifying compliance with limits. For example, views are divided on whether measurements should be carried out in fair weather, foul weather, or both. Practically every major factor is subject to statistical variation. It is recognized that international discussions cannot fully resolve these problems. Some countries have, however, laid down mandatory standards on limits of interference from power lines.

There is general agreement by countries participating in CISPR that guidance should be given by it on a simple and effective method for deriving limits on a national basis, taking into account particular conditions the regulatory authority may wish to adopt. Furthermore, it is agreed that the method of deriving limits should be illustrated by examples based on reasonable minimum radio signal levels, adequate receiver installations and on practical and economical power line designs. The method should enable assessment of the effects of power lines on radio reception under any particular conditions.

Since a number of arbitrary assumptions about random parameters shall be made, which may differ from actual conditions, and since economic factors shall also be considered, any recommended limits cannot assure 100 % protection to 100 % of the radio broadcast listeners or viewers. This fact is generally accepted in standardization.

5.2 Significance of CISPR limits for power lines

CISPR Recommendation 46/1 "Significance of CISPR limits" [26] and CISPR 16-4-3, specify a statistical basis for analysing test data to determine compliance with a CISPR limit for mass-produced appliances.

In the case of noise from power lines and high-voltage equipment, this criterion is not directly applicable. It is however possible to relate it to the statistical distribution of noise due to the variation of atmospheric conditions. For power lines, high-voltage substations as well as for high-voltage equipment, the CISPR limit recommended in the present document may be interpreted as the noise level not exceeded for 80 % of the time. However, as is discussed

in 4.3, this application of the CISPR 80 %/80 % rule would involve a larger number of measurements than is specified in CISPR Recommendation 46/1.

It shall also be realized that an 80 % level for conductor corona noise for d.c. lines will always be a fair-weather level of all climates, whereas for a.c. lines, the 80 % level in moderate climates will usually be a foul-weather level, and for dry climates, it will usually be a fair-weather level.

Figure 12, which shows typical annual all-weather radio noise at 0,5 MHz cumulative amplitude distributions for an a.c. line and a bipolar d.c. line in moderate climates, illustrates this difference between corona noise from a.c. and d.c. lines.

Other criteria, such as average fair-weather noise levels or possibly maximum fair-weather noise levels, could also be the basis for establishing limits for high-voltage direct current (HVDC) lines. Foul-weather noise is normally lower (8.2 of CISPR/TR 18-1); therefore, the fair-weather noise level (50 %) is higher than the foul-weather noise level, but the difference is moderate. The fair-weather noise level should always be the basis for establishing limits for HVDC lines.

Regulatory authorities should keep these facts in mind when deciding on adoption of the 80 % level.

5.3 Technical considerations for derivation of limits for lines

5.3.1 Basic approach

The basic requirement is to maintaining an adequate SNR at the receiving installation for satisfactory reception of broadcast signals. When establishing regulations, it will be the responsibility of the regulatory authority to determine the minimum radio signal strengths to be protected and the SNR that will give satisfactory reception. This publication presents information on acceptable SNR and gives some information on minimum radio signal levels to be protected. It also shows how the protected signal level and the required SNR can be combined with the noise level at the direct or lateral reference distance D_0 or y_0 , respectively, of the power line to develop a "protected distance". This protected distance D_p represents the minimum distance from the line required to protect the minimum radio broadcast signal for a certain percentage of the time. For example, if the 80 % level is chosen as the basis for the radio noise, then this protected distance will be the minimum distance from the line at which the minimum protected signal can be received 80 % of the time with an acceptable SNR. If the average fair weather noise level is the basis for establishing limits, then this protected distance will be the minimum distance from the line at which the minimum protected signal level can be received for 50 % of the time during fair weather with an acceptable SNR.

It should be appreciated that at most locations the radio signal level will be higher than the minimum one and that advantage can sometimes be taken of the directional properties of certain types of receiving antenna to improve the SNR. On the other hand, there will be cases where the distance between the power line, or the high-voltage equipment, and the receiving location will be less than the protected distance. On a statistical basis these factors will often tend to balance each other in such a way as to provide adequate reception even in cases falling within the protected distance. For those so placed who suffer interference, mitigation techniques may be employed such as use of remote antennas or connection to a cable systems.

5.3.2 Scope

5.3.2.1 Power systems

The radio noise limit discussed in this clause applies to the power system as a whole and not to its individual components such as transformers, insulators, etc. The method of measurement of the noise level of a component is discussed in 4.5, and the relation of this level to that it would produce in a direct distance of 20 m from the nearest phase conductor

(in case of HVAC systems) or positive conductor (in case of HVDC systems) of the overhead power line is discussed in 6.2 of CISPR/TR 18-1.

The noise limits are based on lateral attenuation laws applicable to typical power lines and on the appropriate CISPR measuring methods and instruments referred to in Clause 4. No well-established data are presently available for HVAC substations or HVDC converter stations. For simplicity, however, the same laws may be used as for lines, the reference distance being taken as 20 m from the perimeter fence of the substation or converter station. It should be noted that only persistent noise from HVAC substations or HVDC converter stations is considered. Transient noise, such as that due to interruption of a power circuit or due to turn-on and turn-off sequences of the valves of a HVDC converter station, is not included.

The information in this clause is hence valid for persistent noise from HVAC lines and substations operating at voltages from 1 kV to 800 kV, and for HVDC lines and converter stations operating at voltages from 1 kV to ± 750 kV.

5.3.2.2 Frequency range

The frequency range is from 0,15 MHz to 300 MHz, covering specifically the a.m. broadcast frequency bands between 0,15 MHz and 1,7 MHz and the v.h.f. television and f.m. radio frequency bands between 47 MHz and 230 MHz. The intent is to provide protection to "reasonable" wanted signal levels of these services. Since power lines normally produce negligible interference to broadcast reception above 300 MHz and since there is only limited information on noise levels at these frequencies, the bands above 300 MHz are not included at this time.

The definition of "reasonable" wanted radio signal levels will vary with the type of service and part of the world. The International Telecommunication Union (ITU) considers three regions (1, 2 and 3). Regions 1 and 3 are further divided into three zones (A, B and C) based on climatic conditions. Figure 10 shows these regions and zones. Within each region and zone, there are specific transmitter power levels, minimum protected signal levels, required co-channel and adjacent channel protection ratios, etc.

In particular, the low and medium frequency broadcast bands 0,15 MHz to 0,28 MHz and 0,5 MHz to 1,7 MHz are regulated by the ITU. However, existing practices regarding minimum signal levels to be protected and also regarding protection ratios often differ from the latest recommendations of the ITU. In North America the 0,5 MHz to 1,7 MHz band is regulated by the North American Regional Broadcasting Agreement (NARBA). It should be noted here that some of the differences result from differences in broadcasting philosophies. In Europe, for example, it is usual to have a few omnidirectional transmitters of high power to cover an entire country, In North America, on the other hand, there is a multitude of individual stations, often with highly-directional antenna arrays aiming a signal at a particular city or region of the country. Transmitter power is usually limited to 50 kW and protected received signal levels are generally lower than those specified in Europe.

NOTE The upper and lower limits of the various frequency bands, used for broadcasting and given here, are approximate values. Exact values vary from one region to another and are subject to periodic revisions. (See reference [21] for more details.)

5.3.3 Minimum broadcast signal levels to be protected

Individual national authorities should determine the minimum signal levels to be protected from power line noise related to appropriate weather conditions. For the low frequency and medium frequency bands, the ITU [22] has recommended minimum field strengths necessary to overcome natural noise (atmospheric noise, cosmic noise, etc.). For broadcast planning purposes, the ITU has also recommended for information only, nominal usable field strengths. Annex C gives recommended values for both the minimum and the nominal usable field strengths.

Since natural noise levels vary with time and geographical location, signal levels below these values can sometimes be received satisfactorily and at other times unsatisfactorily, irrespective of power line or other man-made noise.

For the v.h.f. bands, the International Radio Consultative Committee (CCIR) recommended minimum signal levels for region 1 are as follows:

Table 2 – Minimum usable broadcast signal field strengths in the v.h.f bands according to CCIR

Frequency band	Minimum signal strength
Television band I 47 MHz to 68 MHz	48 dB(μ V/m)
FM radio band II 87 MHz to 108 MHz	48 dB(μ V/m) (for mono) 54 dB(μ V/m) (for stereo)
Television band III 174 MHz to 230 MHz	55 dB(μ V/m)

In North America, signal levels at the edge of the service area of a broadcasting station are specified by NARBA and other standards [23 to 25]. These levels are given in Annex D.

It is generally accepted that when criteria for the protection of TV in bands I and III have been fixed, f.m. monoaural sound radio broadcasting is automatically protected. The protection requirements for f.m. stereo sound radio broadcasting are under consideration. Similarly, the intermediate bands, such as short wave, are automatically protected to the extent as is the medium wave radio broadcast band. However, in certain cases, there may be telecommunication services requiring different protection. These should be taken into account by national authorities when limits are being considered.

It should be borne in mind that all of these minimum signal levels are related to protection against interference from other radio signals or from natural noise. Interference from power line noise has not been considered so far.

With the widely differing values adopted for usable signal levels for different zones of the world, daytime and night time, the term "reasonable radio signal level" has to be established with regard to the factors relevant to the different levels. It is inevitable that if low levels are adopted, radio noise from power lines should be viewed in comparison with other sources of interference and the protected distance between the power line and receiver should be increased and/or the acceptable SNR should be reduced.

5.3.4 Required signal-to-noise ratio

5.3.4.1 AM audio broadcasting in the range below 30 MHz

No exact recommendations as to acceptable SNR have yet been devised for noise from power lines. For planning purposes, the ITU recommend a wanted-to-interfering signal ratio of 30 dB. NARBA levels are based on a ratio of 26 dB.

For similar ratios, power line noise may represent somewhat less objectionable interference than does any co-channel interference.

For a.c. lines, the technical literature contains results of a number of investigations of the required SNR for satisfactory reception in the presence of power line noise. These are summarized in Annex E. The required ratios for various qualities of reception from "entirely satisfactory" to "speech unintelligible" are provided. National regulatory authorities may specify the quality of reception they wish to protect. It should be borne in mind that the SNR depends largely on the receiver bandwidth. The ratios given in Annex E are based on the signal being measured on an average or r.m.s. reading meter and the noise being measured on a CISPR measuring receiver with a quasi-peak (QP) detector. For a.m. reception, the

CISPR measuring receiver has a 9 kHz bandwidth. When measured with the CISPR measuring receiver, the reading obtained from a.m. radio signals will be about 3 dB higher than the reading obtained from the respective un-modulated constant wave (CW) carrier signal, depending on the modulation depth, since the QP detector produces an output which approaches the peak of the modulation envelope. This effect will, of course, not appear if the measurements are made on an un-modulated signal. Here, the signal envelope level coincides with the amplitude of the CW carrier signal.

As for a.c. lines, the technical literature [10, 11, 12, 27 and 28] contains results of a number of investigations of the required SNR for satisfactory reception in the presence of d.c. power-line noise. However, the number of investigations is much less for d.c. lines than for a.c. lines, and the d.c. SNR tests are not as consistent with each other as are the a.c. SNR tests. Some of the investigations have shown that in the case of d.c. lines the measured SNRs could be as much as 9 dB lower than for a.c. lines to give the same subjective impression, whereas other investigations have seen little difference between a.c. and d.c. lines. Until these discrepancies can be resolved by further research, it is recommended that a.c. SNR data be used by national regulatory authorities in developing limits for d.c. lines.

5.3.4.2 Television broadcasting in the range above 30 MHz

The required SNRs for television reception are less definite than those for audio radio reception. For the European television standard, 40 dB appears to be generally acceptable (the radio frequency bandwidth of the CISPR measuring receiver being 120 kHz). However, tests carried out in the United Kingdom with a positive modulated black and white picture showed that this value could be reduced by up to about 5 dB. For the North American televisions standards, several limited tests have suggested 40 dB for black and white television [17]. Tests on colour television are currently being carried out. Further consideration of all these issues may be necessary.

The repetition rates of noise pulses due to corona and to gap-type discharges may differ considerably. This may have a large influence on the degree of interference produced on a television picture. Although there is not much data available, this should be considered when establishing acceptable SNRs for reception of television radio broadcast services.

5.3.5 Use of data on radio noise compiled during measurements in the field

5.3.5.1 Attenuation laws

The rate of lateral attenuation of radio noise, for direct distances D between about 20 m and 100 m from the nearest conductor of a line, varies in different frequency ranges and also depends on the configuration of the line. The following approximate values should provide satisfactory results:

- 0,15 MHz to 0,4 MHz, noise level decreases as $D^{-1,8}$;
- 0,4 MHz to 1,7 MHz, noise level decreases as $D^{-1,65}$;
- 30 MHz to 100 MHz, noise level decreases as $D^{-1,2}$;
- 100 MHz to 300 MHz, noise level decreases as $D^{-1,0}$.

Presumably, the factor 1,65 is somewhat valid between 1,7 MHz and 30 MHz. The information for the 30 MHz to 300 MHz band is based on few measurements only, but it shall be appreciated that the mechanism and also the attenuation law are dependent on the type of noise source, for example conductor corona or gap-type discharges at hardware.

The reference noise levels E_0 measured 2 m above ground level and belonging either to the lateral reference distance y_0 of 15 m or also to the direct reference distance D_0 of 20 m may, therefore, be corrected to the protected distance, using the following correction formulae:

$$0,15 \text{ MHz to } 0,4 \text{ MHz} \quad E_p = E_0 - 36 \lg \frac{D_p}{20}$$

$$0,4 \text{ MHz to } 1,7 \text{ MHz} \quad E_p = E_0 - 33 \lg \frac{D_p}{20}$$

where

E_p is the radio noise level at protected distance, in dB(μ V/m)

E_0 is the reference radio noise level measured at 2 m height above ground, either in the direct reference distance D_0 of 20 m or in the lateral reference distance y_0 of 15 m, in dB(μ V/m)

D_p is the protected distance (m).

NOTE Numerous measurements in the medium frequency band have demonstrated that, on average, the noise level decreases as $D^{-1,65}$ close to the line (see 4.2 of CISPR/TR 18-1). For greater distances, however, some measurements have shown that it decreases as D^{-1} . For any distance greater than about 100 m, a more accurate value for the noise level E_p may be given by:

$$0,4 \text{ MHz to } 1,7 \text{ MHz:} \quad E_p = E_0 - 23 - 20 \lg \frac{D_p}{100} \quad D_p > 100 \text{ m}$$

There is a degree of uncertainty as to the lateral distance beyond which this formula applies. In most cases, however, at distances beyond 100 m the noise level will be so low that broadcast reception will not be affected.

5.3.5.2 Normalization of measurement data to the reference distance D_0 or y_0

Whenever possible, measurements should be made 2 m above ground level at a distance of 20 m (direct distance) or 15 m (lateral distance) from the reference point. When this is not possible, the above formulae may be used to convert measured values taken at other distances to the reference distance of 20 m and 15 m, respectively. Measurements should also be taken at distances other than 20 m and 15 m, respectively, for verification purposes. In all cases, measured profiles of lateral attenuation are greatly preferable to the use of correction formulae (see 5.3.5.1).

5.3.6 Use of data obtained by prediction of the radio noise from high-voltage overhead power lines

5.3.6.1 General

Beneath assessment of measurement data obtained at operational lines, reliable prediction of noise levels is important as no corrections of line design or construction can economically be made after the line has been built. Once the line is in service, there are several alternative measurement procedures by which this predicted level may be verified. The choice of method will depend on the length of time available for the measurements and on the degree of accuracy required.

5.3.6.2 AC power lines

For an a.c. power line, the approximate radio noise level due to conductor corona may be predicted by use of an empirical formula, such as is presented in 5.2 of CISPR/TR 18-3 or with the help of the catalogue (see Annex B of CISPR/TR 18-1). The formula is

$$E = 3,5 g_{\max} + 12 r - 30 \quad \text{in dB}(\mu\text{V/m})$$

where

E is the radio noise field strength at the direct distance D_0 of 20 m from nearest conductor of the proposed line in dB(μ V/m);

g_{\max} is the numerical value of the maximum voltage gradient at the conductor surface, in kV/cm;

r is the numerical value of the radius of conductor or subconductor, in cm.

At given frequencies different from 0,5 MHz, especially if a signal at a specified broadcast frequency is to be protected, the calculated radio noise level should be corrected according to the following formula (see also 4.3.2 and Figure B.14 of CISPR 18-1):

$$\Delta E = 5 [1 - 2 (\log 10 f)^2] \quad \text{in dB}$$

where ΔE is the deviation (in dB) of the radio noise level at the given frequency from the reference frequency of 0,5 MHz and f is the numerical value of the given frequency, expressed in MHz, for which the formula is valid over the range 0,15 MHz to 4 MHz.

5.3.6.3 DC power lines

For a d.c. power line, the approximate radio noise field strength due to conductor corona may be predicted by use of the following empirical formula (see 8.2 of CISPR/TR 18-1) in fair-weather and at 0,5 MHz.

$$E = 38 + 1,6 (g_{\max} - 24) + 46 \lg r + 5 \lg n + 33 \lg \frac{20}{D} \quad \text{in dB}(\mu\text{V/m})$$

where

E is the field strength of the radio noise in dB($\mu\text{V/m}$);

g_{\max} is the numerical value of the maximum surface gradient of the line, in kV/cm;

r is the numerical value of the radius of conductor or subconductor, in cm;

n is the number of subconductors;

D is the numerical value of the direct distance between antenna and nearest conductor, in m.

At given frequencies different from 0,5 MHz, especially if a signal at a specified broadcast frequency is to be protected, the calculated radio noise level should be corrected according to the following formula (see also 4.3.2 and Figure B.14 of CISPR 18-1):

$$\Delta E \text{ (dB)} = 5 [1 - 2 (\log 10 f)^2] \quad \text{in dB}$$

where ΔE is the deviation (in dB) of the radio noise level at the given frequency from the reference frequency of 0,5 MHz and f is the numerical value of the given frequency, expressed in MHz, for which the formula is valid over the range 0,15 MHz to 4 MHz. This correction is basically derived from a.c. lines and is also applicable to d.c. lines, until further experience is achieved.

It should be noted that the prediction formula for the radio noise level given above represents the 50 % fair-weather value. In order to achieve the 80 % all-weather value, another 3 dB to 4 dB should be added to the formula.

5.4 Methods of determining compliance of measured data with limits

5.4.1 Long-term recording

This is the most precise method for evaluating the noise level produced by a power line but it takes a long time to obtain the results. A noise-recording station is set up close to the power line under investigation and continuous measurements are made for at least one year. The suitability of the recording site shall be checked by means of measurements at various points along the line. The results are plotted on a probability graph of the type shown in Figure 3 of CISPR/TR 18-1. At the percentage of time that has been selected for specifying the noise, the level is read from the graph.

5.4.2 Sampling method

This is a practical and accurate method that follows the spirit of CISPR Recommendation 46/1 [26]. At least 15 or preferably 20 or more individual sets of measurements of noise level are carried out at various locations along the line and under various weather conditions. The selection of different weather conditions should be more or less in proportion to the percentage of time each weather condition exists in the area of the power line. These measurements are then analyzed to give the noise level that will not be exceeded for 50 %, 80 %, or 95 % of the time, with an 80 % confidence, according to the chosen criterion (see 5.3.1).

The sampling method is fully described in 4.3 for the case where the chosen criterion is the 80 % level.

5.4.3 Survey methods

If time or any other reason does not allow either of the above methods to be used, the alternative of making measurements in fair weather or heavy rain (in case of a.c. lines) and in fair weather (in case of d.c. lines) may be considered. This can be adequate when conductor corona is the main noise source and when the radio noise distribution curves for the particular type of line for the all-year-round weather conditions are available. These curves could, for instance, have been obtained from previous accurate measurements on the actual or on the same type of line under similar climatic conditions. Preferably three distribution curves should be available; (1) under fair weather conditions, (2) under heavy rain and (3) under all-year-round weather conditions. Statistical distributions are discussed in 4.3.4 of CISPR/TR 18-1.

NOTE It should be noted that the methods outlines in the following paragraphs may not apply to lines below 72,5 kV in cases where conductor corona is not the major source of radio noise.

For a.c. lines, the 80 % all-weather value is in general 5 dB to 15 dB higher than the 50 % fair-weather value, depending on the climate.

For d.c. lines, the 80 % all-weather value is in general about 3 dB higher than the 50 % fair-weather value.

Fair-weather measurements have to be made at various locations along the line and at different times. From the results, the 50 % fair-weather level is deduced and used as a reference in the set of curves mentioned above. From the curves the all-weather 80 % value can then be assessed. The success of this method is dependent on the reliability of the distribution curves.

Since the radio noise level due to conductor corona is relatively stable and reproducible during heavy rain, these measurements are not required to be taken at separate times. Foul-weather measurements at a.c. lines should also be made at various locations along the line. For a.c. lines, the 50 % steady, heavy, rain level is deduced from the results of the measurements and used as a reference in the set of distribution curves to assess the 80 % all-weather level. Here also the success of the method is dependent on the reliability of the distribution curves, although it is considered that the assessment of the 80 % all-weather value from the heavy-rain measurements is more reliable than the assessment from the fair-weather measurements. In general, the 80 % all-weather level is about 5 dB to 12 dB lower than the 50 % steady, heavy, rain level.

5.4.4 Alternative criteria for an acceptable noise level

One of the alternative criteria for acceptable noise levels, as discussed in 5.2, may be used. If, for example, the average fair-weather noise level is chosen, then a series of measurements should be carried out during typical fair-weather conditions. At least three measurements should be carried out at three different locations long the line. If time permits, this should be repeated on another day. The average of all the measurement values will be considered to represent the average fair-weather noise level of the line.

5.5 Examples for derivation of limits in the frequency range below 30 MHz

5.5.1 Radio reception

5.5.1.1 General

Examples of the calculation of limits are given below based on the assumptions discussed in the preceding sub-clauses. Limits could also be calculated for different assumptions in respect of signal level, SNR and distance from a power line. Conversely, for a given level of noise, the minimum acceptable distance, for satisfactory reception of a given signal strength, could be calculated.

It should be borne in mind that the lateral attenuation laws quoted are average values. They depend on factors relating to both line design and local conditions. They may change with distance and should not be used for distances materially beyond those assumed in this sub-clause.

Furthermore, it should be remembered that radio-noise is generally measured so far at a frequency of 0,5 MHz. If a signal at a specified broadcast frequency is to be protected, the measured values should be corrected for the given frequency according to 4.3.2 and Figure B.14 of CISPR/TR 18-1. For example, at 1 MHz, the noise level would be about 5 dB to 6 dB lower.

5.5.1.2 Principle

There are four parameters involved in the specification of radio noise limits (see Figures 11a and 11b):

- the minimum wanted radio signal level to be protected;
- the minimum acceptable signal-to-noise ratio (SNR);
- the reference noise level, represented by E_0 , at 2 m height above ground, during prescribed weather conditions;
- the "protected distance", that is, the minimum distance from the line at which the signal can be satisfactorily received.

If any three of these parameters are specified, the fourth can be determined. Two examples will demonstrate this.

5.5.1.3 Example 1

If the value of the noise level at the direct or the lateral reference distance, the protected signal level and the required SNR are all known, the protected distance from the power line for satisfactory radio reception in the low and medium frequency bands may be calculated from the formula given in Annex F:

$$D_p = 10^{\left(\frac{E_0 - E_p}{K} + 1,3 \right)}$$

where

E_0 is the reference radio noise level measured at 2 m height above ground, either in the direct reference distance D_0 of 20 m or in the lateral reference distance y_0 of 15 m, in dB(μ V/m)

$E_p = S_p - R_p$ is the acceptable noise level at D_p , in dB(μ V/m);

R_p is the required signal-to-noise ratio (SNR), in dB;

S_p is the protected wanted radio signal level, in dB(μ V/m).

E_p depends on E_0 and D_p according to the attenuation formula given above:

$$E_p = E_0 - k \lg (D_p/20) \text{ in dB}(\mu\text{V/m})$$

where factor k has a value of 36 and 33, for low frequency (l.f.) and for medium frequency (m.f.) bands, respectively.

In the m.f. band, this formula is accurate for distances up to about 100 m.

As an example, the distance from a given power line at which a wanted radio signal of 72 dB($\mu\text{V/m}$) at 1 MHz may be received with a SNR of 35 dB is required. The line noise measured by the standard CISPR method is found to be 50 dB($\mu\text{V/m}$). The following calculation is made:

Protected wanted radio signal level at 1 MHz	$S_p = 72 \text{ dB}(\mu\text{V/m})$
Required signal-to-noise ratio (SNR)	$R_p = 35 \text{ dB}$
Acceptable noise level at protected distance from line	$N_p = S_p - R_p$
	$N_p = 37 \text{ dB}(\mu\text{V/m})$
Measured noise level at the lateral or direct reference distance, at 0,5 MHz	50 dB($\mu\text{V/m}$)
Noise level at 1 MHz (The 6 dB correction comes from Figure B.12 of CISPR/TR 18-1)	$E_0 = 50 - 6 = 44 \text{ dB}(\mu\text{V/m})$
Protected distance	$D_p = 10^{\left(\frac{44+35-72}{33}+1,3\right)}$

Therefore, the protected distance is $D_p = 32 \text{ m}$ from the nearest conductor of the line.

5.5.1.4 Example 2

In this second example a broadcast signal at 1 MHz, 65 dB($\mu\text{V/m}$), is to be protected with a SNR of 30 dB at distances greater than 100 m from the power line. The acceptable reference noise level E_0 is calculated as follows:

Protected wanted radio signal level at 1 MHz	65 dB($\mu\text{V/m}$)
Acceptable noise level at protected distance from line	65 – 30 = 35 dB($\mu\text{V/m}$)
Attenuation from 20 m to 100 m	$33 \lg \frac{100}{20} = 23 \text{ dB}$
Acceptable reference noise level, at 1 MHz	35 + 23 = 58 dB($\mu\text{V/m}$)
Therefore, acceptable reference noise level at CISPR reference frequency (0,5 MHz) (The 6 dB correction comes from Figure B.12 of CISPR/TR 18-1.)	58 + 6 = 64 dB($\mu\text{V/m}$)

5.5.2 Television reception, 47 MHz to 230 MHz

This is under consideration. Insufficient information is presently available to permit presentation of meaningful examples.

5.6 Additional remarks

Most field tests to date have been carried out in the low and medium frequency bands. Therefore, any data presented on the v.h.f. band should be considered as provisional and major conclusions should not be based on it. This whole subject is still under consideration.

If limits are based on noise levels measured and statistically evaluated in accordance with 4.5, they also represent statistical values not exceeded for 80 % of the time. For conductor corona noise it should be noted that these values are significantly higher than average fair-weather levels. This factor should be taken into account when these values are compared with standards for typical fair-weather conditions laid down in various countries.

As in the case of other sources of possible interference for which CISPR limits exist, examples of limits presented here are based on the requirements for the protection of broadcast radio reception for the large majority of listeners or viewers under conditions prevailing at the majority of sites during most of the time. Such values cannot cater for the few exceptional cases where a number of unfavourable factors coincide.

Practice has shown that acceptable noise levels as presented in this clause can be met with well-maintained power lines of adequate design and construction. Indeed, considerably low noise levels are found on many operational lines where requirements other than radio noise lead to designs with larger conductor sizes (for example high current-carrying capacity). It is considered that the methods of deriving limits indicated in this clause represent good engineering practice and could serve as the basis for establishing such limits.

5.7 Technical considerations for derivation of limits for line equipment and HVAC substations

5.7.1 General

The principle for establishing limits of radio noise voltage for line insulators and hardware and substation plant and hardware in the l.f. and m.f. bands shall be that their contribution to the aggregate noise level of a transmission line is negligible. This is applicable to a.c. lines whose conductors are subjected to surface gradients of about 12 kV/cm to 24 kV/cm or higher. This principle pre-supposes coordination between noise produced by insulators and hardware on the one hand and noise produced by line conductor corona on the other hand. For other a.c. lines, with a lower surface gradient, the noise voltage for line equipment shall be at least as low as the noise voltage for equipment used on lines with a surface gradient of about 12 kV/cm. This principle is applicable to d.c. lines but no figures of gradient are quoted as the relationship between conductor corona noise and noise produced by insulators and hardware is not well established (see 8.2 of CISPR/TR 18-1) the corona noise being higher in dry weather and lower in wet weather. Subclause 4.5 of this technical report describes the CISPR method of radio noise measurement in the laboratory. Subclause 6.2 of CISPR/TR 18-1 gives the correlation between the radio noise voltage measured in μV , in the CISPR test circuit, due to any noise source (as e.g. tested according to 4.5) and the radio noise field strength on site, in $\mu\text{V}/\text{m}$, measured in accordance with the method described in 4.5.

For frequencies above a few megahertz, the correlations between the radio noise voltage and the corresponding radio noise field given in 6.2 of CISPR/TR 18-1 do not apply. This means that no principle for establishing limits for frequencies above the m.f. band has been specified so far for HV overhead power transmission systems.

The radio noise field near a substation, generated by noise sources within the substation, may be the aggregation of the direct radiated field and the guided field due to HF noise currents injected into an overhead line serving the substation. At present, insufficient data are available on the radiated component and therefore only the injected currents will be discussed. Coordination between the injected HF noise currents and the currents produced by line conductor corona applies also in this case.

5.7.2 Current injected by line components and hardware

To evaluate the relative influence of insulators and conductors, it is sufficient to compare the current generated by a complete insulator set with the aggregated current I_L generated by a span of one phase conductor of a line. If the current generated by the insulator set is less than I_L , its contribution to the aggregate noise field of the line will be small; if it is equal to I_L , the increase in level due to the insulators will be approximately 3 dB; if it is greater than I_L , the noise field of the line will be determined mainly by the effect of the insulators.

If the limit of the current of the insulator set is specified as $I_L/3$, that is 10 dB below the level of current I_L , the increase in the field strength level of the aggregate noise field will be about 0,5 dB. This increase is too small to be measured in practice.

In addition to insulator sets, other components and hardware such as spacers, vibration dampers and aircraft warning devices have to be considered. If for any one of these types of component or hardware there are N items per span the radio noise level per item should not be greater than $1/\sqrt{N}$ times the level for the insulator set.

The aggregate radio noise current per span from all these components and hardware should, according to experience, be determined by quadratic summation of the individually measured currents.

5.7.3 Current injected by substation equipment

The equipment is considered as a generator of radio noise current, as indicated in 6.2 of CISPR/TR 18-1. The problem consists in studying the propagation of the injected current along the line, that is, the attenuation and distortion of the guided electromagnetic field associated with this current. To do this, modal analysis is employed.

A substation normally has more than one associated line each with one or more circuits. For determination of the current injected into one of the circuits, it is necessary to know not only the impedance of all circuits but also the impedance of the substation equipment, consisting of busbars, measuring devices, transformers, capacitors, cables, etc., as seen from the apparatus acting as a current source. The current in the circuit under consideration can then be calculated.

For the worst case, the impedance of the substation equipment could be assumed to be infinite. Then for N pieces of apparatus, each producing the same value of noise current I_0 , and for n outgoing circuits, the current injected into a circuit is

$$I = I_0 \frac{\sqrt{N}}{n}$$

Clearly the case of a substation with only one circuit is the most unfavourable.

If the value of the current calculated in this way is equal to the value of the current produced by line conductor corona, the increase in the radio noise field strength level at the substation terminal tower will be approximately 3 dB but after 1 km or 2 km the additional noise current, and consequently the increase in the field strength, will be insignificant.

5.7.4 Practical derivation of limits in the l.f. and m.f. band

a) Line components and hardware

The rigorous procedure is as follows: starting from the graph of the excitation function and the matrix of the line capacitances (see 5.2 of CISPR/TR 18-1), the current I injected per unit length of a phase conductor is calculated. To pass from this elemental current I to the

aggregate current, generated by a span of length L , the law of quadratic summation is applied:

$$I_L = I\sqrt{L}$$

When eventually comparing the current level generated by a complete insulator set with the aggregate current level I_L , it is advisable to include a margin of 10 dB in order to ensure a negligible increase in the aggregate level of the noise field strength. The value of insulator noise current level used in the comparison should be the maximum obtained under the normal range of weather conditions for the area over which the proposed line will run.

For practical purposes, a simple relationship can be derived from the formula (6) given in 6.2.2.2 of CISPR/TR 18-1. The current level I from a single insulator set should not exceed the value given by:

$$I = E - 27 - K_1 \quad \text{in dB}(\mu\text{A})$$

where

I is in dB(μA);

E is the permissible radio noise field strength level during reference weather conditions, in dB($\mu\text{V}/\text{m}$), at a direct distance of 20 m from the nearest conductor or the line;

K_1 is the difference in dB between the conductor corona noise level in the reference weather conditions and that in weather conditions in which the maximum insulator noise is generated.

The formula includes the above-mentioned margin of 10 dB.

b) Substation plant and hardware

The total current level I injected into a line by a substation should not exceed the value given by:

$$I = E - 12 - K_2 \quad \text{in dB}(\mu\text{A})$$

where

I is in dB(μA);

E is the permissible radio noise field strength level during reference weather conditions, in dB($\mu\text{V}/\text{m}$), at a direct distance of 20 m from the nearest conductor of the line, derived from the relevant example in 5.5;

K_2 is the difference in dB between the conductor corona noise level in the reference weather conditions and that in weather conditions in which the maximum substation noise level is generated.

This formula is derived from formula (4) given in 6.2.2.2 of CISPR/TR 18-1 for a conductor height h of 15 m and a depth of penetration into the ground P_g of 7 m. No provision has been made for a margin.

At the junction between a line and substation busbars there will usually be an impedance mismatch. This may create standing waves of radio noise on the first few kilometres of the line resulting in a variation of up to ± 6 dB close to the substation. This is not taken into account in the formulae given above.

NOTE 1 These limits are derived from the permissible radio noise field strength for a line.

NOTE 2 The main difficulty in the practical application of this principle is to simulate the service conditions for the test objects in the laboratory. As mentioned in 6.3 of CISPR/TR 18-1, there is at present no agreed procedure for simulating in the laboratory the more common service conditions but the matter is under consideration. Meanwhile, it is proposed that measurements should be made on equipment in a situation closely related to service conditions.

NOTE 3 Limits for individual items of plant, for example switch disconnectors, circuit breakers, etc., cannot be specified in this publication as these items are the responsibility of other bodies. However, the effect of these individual items, when in their service environment, should be in accordance with the limits discussed above.

6 Methods for derivation of limits for the radio noise produced by insulator sets

6.1 General considerations

This technical report gives general procedures for setting up limits of the radio noise produced by overhead lines and substations. In 5.7 technical considerations are given, with reference to low and medium frequency broadcast bands, for the coordination of the radio noise produced by the insulator sets with that produced by the conductors.

The general principle for this coordination is to design the insulator sets in such a way that their noise contribution to the overall noise of the line or of the substation is negligible for any surface condition of the insulators. In this respect, a difference of 10 dB between the radio noise current produced by one span of one phase conductor and that of one insulator assembly is considered as being adequate. In addition, following this principle, the noise current injected into the outgoing lines by the insulator assemblies of a substation, should not increase the intrinsic noise of these lines. To limit any increase to a maximum value of 3 dB, the radio noise current produced by each insulator assembly within the substation should not exceed the value $I_0 = I n / \sqrt{N}$, where I is the line conductor noise current at the substation side, n the number of outgoing lines and N the number of insulator sets in the substation.

The above principle is economically justified when the noise level produced by the conductors is close to the maximum admissible level (e.g. for gradients of the effective voltage greater than 12 kV/cm to 14 kV/cm). For lower conductor noise this principle could be uneconomic and it could be acceptable that the radio noise produced by the insulator sets prevails in respect to the noise produced by the conductors. In this case the limit for the radio noise current of each insulator assembly is directly obtained from the maximum admissible overall level of the line.

According to this technical report and IEC 60437, the verification of the radio noise level of the insulator assembly is at present made with reference to only a standard and reproducible condition of the insulators (clean and dry).

Since the influence of ambient and weather conditions is not the same for conductors and insulators, radio noise limits for insulators established considering only the clean and dry condition may not guarantee acceptable values for other conditions.

This clause intends to give, on the basis of the results of systematic radio noise tests in different countries on various types of insulators, guidance to take into account the effect of the insulator surface conditions in the selection of the radio noise limits of insulator sets. The limits and test procedures suggested are applicable to the cases of insulators to be installed in areas where they will remain clean or slightly polluted. For insulators in polluted conditions, with high humidity and formation of sparks across dry bands, only some indications about possible remedies are indicated.

6.2 Insulator types

The criteria given in this publication are mainly applicable to cap-and-pin type insulators, for which more complete information on the influence of surface conditions on the radio noise performance of insulators is available. For long-rod insulators only a little data can be found in the literature. However, it can be assumed that for this type of insulator the radio noise problem is generally of little concern in clean and slightly polluted conditions; for heavy pollution the conclusions that will be drawn for cap-and-pin insulators can be generally applied to long rod insulators.

In addition, regarding cap-and-pin insulators, for practical reasons the majority of the available data refers to single insulator units. However, as regards dry conditions, the difference between the radio noise voltage levels of polluted and clean insulators obtained on single units is directly applicable also to insulator sets, since the voltage distribution along the

string is being determined by the string capacitances and therefore are not affected by dry pollution. In wet conditions, both for clean and polluted insulators, the differences of radio noise voltage levels in comparison with the dry conditions are generally lower for the strings than for the insulator units considering the better voltage distribution in wet conditions: conclusions on the above differences for insulator units are therefore on the safe side when applied to the insulator sets.

6.3 Influence of insulator surface conditions

6.3.1 General

The analysis of the radio noise behaviour of the insulators in respect of the surface conditions is made with reference to the following classification:

- clean insulators: it is an ideal condition in which the insulators remain completely clean, close to the situation of the present laboratory test according to this technical report and IEC 60437;
- slightly polluted insulators: no important dry-bands are present in wet conditions; it is the most common situation in relatively clean areas after a certain period of service;
- polluted insulators: dry bands are present in wet conditions; it is the situation in service in polluted areas of various pollution severities.

The analysis of the data confirms that it is very difficult to give general conclusions on the effects of surface conditions, due to the great dispersion of the results, especially when the insulators are slightly polluted, and due to the different behaviour of the different types of insulators.

Even with these limitations, it is possible to give some qualitative trends and average quantitative estimations.

The following general considerations apply both to glass and to porcelain cap and pin insulators.

6.3.2 Clean insulators

The radio noise level of insulators decreases with the increase of the relative air humidity for all types of insulators. Figure 13 gives an example of typical trends for individual cap-and-pin insulator units; for insulator strings the influence is more pronounced, considering the favourable effect of the humidity, which linearizes the voltage distribution along the string. In any case, the reduction of the radio noise level with an increase of the humidity is much higher for the insulators than for the conductors, for which this reduction is negligible.

In the presence of condensation without water drops, due to light fog or dew, the radio noise behaviour of a clean insulator is similar to that of the same insulator at very high humidity (i.e. 90 % to 95 %).

The radio noise level of insulators increases in the presence of water drops on the insulator surface (due to rain, thick fog or dew, snow, ice). However, this increase is generally lower than in the case of conductors (10 dB to 12 dB compared to 18 dB to 22 dB).

The radio noise frequency spectrum of clean insulators is similar to that of the conductor.

6.3.3 Slightly polluted insulators

Under slightly polluted conditions, the majority of insulator types show radio noise behaviour, as a function of the relative air humidity, similar to that of the same insulators in clean conditions. However, some types of insulators with particular characteristics, such as high mechanical performances or especially designed for very low radio noise in clean and dry conditions, may present a different behaviour. As regards in particular the insulators with very

low radio noise levels in clean conditions, a great increase of the radio noise level at relative air humidity greater than 50 % to 60 % was found for some of them, as shown by Figure 13.

In the presence of condensation without water drops on the insulators, due to light fog or dew, the radio noise behaviour of a slightly polluted insulator is similar to that of the same insulator at very high humidity (i.e. 90 % to 95 %).

In the presence of water drops (due to rain, thick fog or dew, snow, ice) the radio noise behaviour of a slightly polluted insulator does not appreciably differ from that of a clean insulator.

As in the case of clean insulators, the radio noise frequency spectrum of slightly polluted insulators is similar to that of the conductor.

6.3.4 Polluted insulators

For relative air humidity lower than 60 % to 75 %, the radio noise behaviour of polluted insulators is similar to that of clean and slightly polluted insulators.

For higher humidity or in case of condensation (light fog or dew), the pre-discharge phenomenon across dry bands produces very high noise levels; these levels are not related to those found in clean or slightly polluted conditions; they can only be controlled by drastically reducing the voltage stress (increase in an unrealistic manner of the insulator string length or of the leakage path in respect of that imposed by insulation requirements). Other special remedies, corresponding to limiting the pulses of the leakage current, are the use of special insulators (composite insulators, semiconducting-glazed insulators), greasing or washing of insulators.

In the presence of water drops on the insulators (rain, thick fog and dew) the critical situation is at the beginning, when the insulator is still heavily polluted: here the predominant phenomenon is pre-discharge across the dry bands. After a certain time, depending on the intensity of the rain, fog, or dew and on the shape of the insulator, the radio noise behaviour tends to that of slightly polluted and clean insulators in presence of water drops.

The frequency spectrum of wet polluted insulators with pre-discharges across the dry bands extends to higher frequencies (up to few tens of megahertz) than in the other cases: medium frequency and television reception can be disturbed.

6.4 Criteria for setting up radio noise limits for insulators

6.4.1 General

On the basis of the considerations of the previous clauses the criteria for setting up limits and testing the insulators shall be established with reference to the different areas in which the insulators are to be installed. These areas are:

- Type A areas: areas where the insulators remain clean: they are generally characterized by the absence of contaminating phenomena and frequent natural insulator washing due to rain or high and frequent dew condensation;
- Type B areas: areas where the insulators become slightly polluted: they are generally characterized by low-intensity contaminating phenomena and by cleaning agents such as rain or heavy dew condensation that limit the contaminant accumulation on the insulator surface so that the formation of partial discharges across dry bands appears very seldom;
- Type C areas: areas in which the insulators become polluted so that the formation of partial discharges across dry bands is frequent.

6.4.2 Criterion for insulators to be installed in type A areas

For these areas the present radio noise test on clean and dry insulators is sufficient. The coordination criteria and the margin M of 10 dB indicated in 6.1 guarantees an acceptable radio noise performance of the insulator sets in any atmospheric conditions. Considering the great influence of the relative humidity, the test should be performed in a limited range of humidity (e.g. 50 % to 70 %).

6.4.3 Criterion for insulators to be installed in type B areas

For these area the present test on clean and dry insulators, associated with the coordination criteria and margins indicated in 6.1, is not sufficient to guarantee in all cases an acceptable radio noise performance of the insulator sets in any atmospheric conditions: in fact, as reported in 6.3, in the case of very high humidity or condensation, a great increase of the radio noise level may be found for a few particular types of indicators.

To take account of this fact, it is recommended to maintain the test on clean and dry insulators which has been defined (see this technical report and IEC 60437), easy to perform and well reproducible, but to adopt a greater safety margin that in the case of insulators to be installed in type A areas.

This procedure could be too conservative for many insulators. For this reason, the choice of the most appropriate additional safety margin should be made on a statistical basis taking into account the reciprocal radio noise behaviour of conductor and insulator in the various surface and ambient conditions and the frequency of occurrence of each condition for the line under consideration. As guidance, considering the most common types of insulators and with reference to an average moderate climate, an additional safety margin M of 8 dB (18 dB in total) should be adequate for high-voltage lines and substations.

NOTE The possibility of introducing an alternative procedure, consisting of a test on slightly polluted insulators at high humidity (75 % to 90 %) was also considered. It is not recommended because it requires a new test procedure to be set up, which is difficult and expensive. It is, in fact, difficult to obtain in the laboratory a reproducible pollution layer duplicating the natural light pollution taking into account the fact that the radio noise level depends on the distribution of the pollution deposit; in addition, it would be necessary to perform the test in a climatic room, in order to maintain the relative humidity in the required range. Some attempts have been made to perform the test on insulators artificially polluted with slurry which maintains its humidification during the test: for light pollutant layers, this procedure is, however, quite complex and requires very sophisticated methods of pollution application. For these reasons, tests on slightly polluted insulators can only be considered for research purposes.

6.4.4 Criterion for insulators to be installed in type C areas

For these areas, the present radio noise test on clean and dry insulators does not give any indications of the radio noise behaviour of the insulators in wet and polluted conditions. For these conditions, a specific test on artificial heavily polluted insulators should be considered. It is, however, difficult to control the radio noise level of wet polluted insulators, which depends on the design of the insulators, the type of deposit and the non-uniform distribution of the pollution deposit on the insulator surface and along the string.

In 6.3.4 possible remedies have been indicated, which may involve drastic reduction of the voltage stress, use of special insulators, greasing or washing.

6.5 Recommendations

In the light of present experience it is possible to give the following recommendations (Table 3) for test methods and radio noise limits to be applied to insulator sets to be installed in the different areas defined in 6.4.

It is worth remembering that the recommended procedure consists in tests on clean and dry insulator sets, both for insulators to be used in areas where they will remain clean (type A areas), and for those to be used in areas where they will become slightly polluted (type B areas). The only difference is that lower limits of the radio noise voltage are required for insulators to be installed in type B areas.

For the evaluation of these limits the margin M indicated in 6.4 between the total electric field strength level E_c produced by the conductors and the total field strength level E_i produced by the insulator sets of the line is applied ($M = 10$ dB and $M = 18$ dB, for insulators to be used in type A and type B areas, respectively). The relationship between the total field strength level E_i produced by all the insulator sets and the radio noise current level I_s produced by a single insulator set is given by the following simplified formula (formula (6)) of 6.2.2.2 of CISPR/TR 18-1):

$$E_i = I_s + A + (D - 10 \lg (s/500)) + C \quad \text{in dB}(\mu\text{V}/\text{m})$$

where

A takes into account the splitting of the injected current I on either sides of the injecting point (in the most common case, for a relative long line, $A = -6$ dB);

$(D - 10 \lg (s/500))$ takes into account the aggregation of the noise source along the line for span lengths s in metres, at a length of 500 m (average values of D lie between 10 dB and 12 dB);

C is the field factor that gives the correlation between the levels of the noise field strength and the noise current (at a direct distance of 20 m from the line and for an average line configuration, C lies between 7 dB and 12 dB);

E_i is given in dB($\mu\text{V}/\text{m}$), and I_s in dB(μA).

As an example, considering the average values given above for the parameters of the formula, and a span length of 500 m,

$$I_s = E_i - 17 \quad \text{in dB}(\mu\text{A}).$$

Since it is used to express the radio noise current level I_s , produced by a single insulator set in terms of the radio noise voltage level V in dB(μV) produced across a resistance of 300 Ω , the resulting voltage level V is

$$V = I_s + 20 \lg (300) = E_i + 33 = E_c - M + 33 \quad \text{in dB}(\mu\text{V})$$

and this relationship originates from the radio noise voltage limits indicated in the following Table 3.

Table 3 – Recommendations for the radio noise voltage limits and for the test methods for insulator sets installed in different areas

Type of area where the insulator will be installed (Clause 4)	Radio noise voltage limits QP detector according to CISPR 16-1-1 (in dB(μV) across 300 Ω)	Test methods
A	$E_c + 23$	According to this technical report and IEC 60437 (on clean and dry insulators)
B	$E_c + 15$	
C	Indications for limits and test procedures applicable to insulators to be installed in type C areas cannot be given at present. Possible remedies, in the case of non-acceptable radio noise levels, are: the reduction of the voltage stress by means of longer insulator strings, or leakage paths; the use of composite insulators; the greasing or periodic washing of the insulator sets.	
E_c = 50 % fair-weather radio noise voltage level produced by the conductor at the direct distance of 20 m from the outer phase of the line in dB(μV/m)		
<p>NOTE 1 The limits reported are applicable to lines characterized by conductor noise level close to the maximum admissible level (voltage gradients higher than 12 kV/cm to 14 kV/cm).</p> <p>For lines of special design (having particularly low conductor noise), the direct application of the limits indicated could lead to uneconomical requirements for the insulators; to avoid this, the formula could be utilized also per these lines provided that if E_c is intended not as the conductor noise of the line under consideration, but the one produced by the conductors of a line of the same category (voltage level, tower geometry, region, etc.) with normal conductor design.</p> <p>NOTE 2 The values apply to line insulators; similar approaches can be applied to substation insulators in respect to the noise in the substation itself and the noise conducted into the outgoing lines.</p>		

7 Methods for derivation of limits for the radio noise due to HVDC converter stations and similar installations

7.1 General considerations

There are principally two different sources of radio noise generation in HVDC converter stations and similar high-voltage installations, such as static var compensators (SVCs), incorporating thyristors in their operation. First, corona discharges on conductors, insulators, and hardware cause noise, similar to that in a.c. systems. This corona noise can be easily held to acceptable levels by proper electrical design of the busbars and hardware in the station. Second, the converter or control valves cause interference due to the rapid breakdown of the voltage between anode and cathode during valve firing. This noise, unlike noise due to corona, is independent of weather but is influenced by the characteristics of the converter equipment and by the valve operating conditions.

Without any suppression measures, the radio noise level from the converter or the control valves could be intolerable and it is, therefore, necessary to reduce this level to an acceptable value with appropriate methods like those indicated in 7.3.3 and 7.4.2.

An evaluation of the radio noise radiated directly by a converter valve can be performed by means of the analytical methods of calculation proposed in the literature [34], [35], [36], [37]. Reference [34] also gives methods of calculating the high-frequency oscillations in the station using simplified equivalent circuits.

The disturbance levels shown in Figures 15 to 22 are not to be considered as typical reference values. They are simply given as examples of the influence of the different parameters considered (distance from the station, technology of the valves, etc.) on the levels of disturbance.

7.2 Sources of interference

7.2.1 Mechanism of radio noise generation

An HVDC converter station is generally made up of several converter groups. Each one of these groups normally comprises six valves (thyristor valves and also mercury arc valves in the past) fired cyclically at the power frequency. For obtaining higher voltages, several bridges may be connected in series per pole. The bridges are connected to the converter transformers on the a.c. side, and to the smoothing reactors on the d.c. side. A large amount of auxiliary equipment is also connected on both sides of the bridge circuits.

An SVC installation usually consists of a set of thyristor controlled reactors (TCRs) and thyristor switched capacitors (TSCs). The physical arrangement of the thyristor valves is similar to that of HVDC converter stations. The thyristors for the TCRs are switched over a range of firing angles to control the current to the reactors, while those for the TSCs are switched at a fixed point-on-wave (zero cross-over).

During the normal operation of such schemes, each valve is turned on and off once in every cycle of the alternating voltage. The valve firing thus occurs thus 6 times per cycle of the power frequency for a 6-pulse converter or SVC installation, and 12 times for a 12-pulse converter. The attenuation of the high-frequency currents generated by valve firing is so rapid that each pulse can, from a radio noise standpoint, be considered fully damped before additional pulses from other valves are injected in the system. For this reason and due to the spread in the firing angles even if valves in different groups have the same transformer connections, the total level of the radio interference generated is not significantly different from that generated by a single valve.

The switching times during both turn-on and turn-off are very small, being usually of the order of a few microseconds. Thyristor valves, when fired, may have a voltage collapse time of up to 25 μs , compared with 1 μs for mercury arc valves. The reason for this is the use of damping circuits within the thyristor valve and the fact that the thyristor valve is composed of a number of thyristors connected in series. As a consequence the generated noise is in principle lower for thyristor than for mercury arc valves. Figure 14 shows the frequency spectra, recorded in the laboratory, of two transient phenomena of the same amplitude with rise times of 1 μs and 25 μs (average values for mercury arc and thyristor valves, respectively).

During both turn-on and turn-off of the valve, transient voltages and currents appear in the system as a result of the redistribution of the energy stored in the reactive elements before a new steady state is reached. During turn-off, most of the energy is stored in the inductance of the transformer windings. Thus, the transition to the new steady-state condition is achieved essentially at the relatively low natural frequencies of the transformer and the system. During turn-on, however, the energy to be redistributed is stored essentially in the various stray and lumped capacitances. This produces a rather complex system of oscillations whose spectrum depends not only on the amplitude and shape of the voltage collapse across the valve, but also on the layout of the connections and equipment connected. The noise spectrum extends in frequency up to a few megahertz.

This radio noise may be emitted directly from the valves and associated equipment comprising, in this instance, mainly the feeders and the busbars of the converter station. These busbars will often be of considerable length and well able to act as efficient radiators. The converter station will be, of course, connected to incoming and outgoing a.c. and d.c. circuits and these may consist of overhead lines. The radio noise will be guided and emitted from such overhead lines.

7.2.2 Influence of station design on radio interference

As anticipated, the radio interference generated is influenced by the steepness of the valve firing voltage. For this reason, the radio noise level generated by thyristor valves will be lower than that produced by mercury arc valves.

Besides the amplitude of the voltage collapse at the valve firing and the time of this collapse, the noise from the valves is primarily influenced by the height and capacitance to ground of individual valves. The radio interference has therefore a tendency to increase by the voltage and current rating of the valves as an increased rating means increased valve size. On the other hand, the noise is little influenced by the number of operating valves in a station. This has also been confirmed by measurements in operating converter stations.

The switchyard layout and the height and length of the busbars have also a great influence on the generated disturbance. A compact design of the switchyard will therefore have favourable effects on the radio noise generation. A practical solution consists of moving the converter transformers into the valve hall and using the transformer bushings as valve hall bushings. This solution lowers the radio interference significantly because the radiating loop between valves and transformers is small as it is entirely located inside the electromagnetically screened valve hall. Additional reduction of the radio interference from connecting lines could be achieved if the converter transformers were built with grounded electrostatic screens between the two windings.

Oil-cooled thyristor valves will require a metallic tank. In this case, the valve circuits will be effectively screened electromagnetically, and the radio interference problem will be significantly reduced.

7.3 Radiated fields from valve halls

7.3.1 Frequency spectra

Examples of frequency spectra due to direct radiation from a converter station are given in Figures 15 and 16 for converter stations equipped with mercury arc and thyristor valves, respectively. No qualitative differences can be remarked between the radio noise spectra generated by mercury arc and thyristor valves converters.

7.3.2 Lateral attenuation

The interference from the valve hall is dominated by direct radiation from the converter valves and their connections to other pieces of equipment. The physical size of the radiating loops is small compared to the wavelength of the noise in the range of frequencies of interest (0,15 MHz to 30 MHz). Therefore, the converters can, from a radiation standpoint, be treated as vertical electrical dipoles (with a pure capacitive radiation impedance). As a first approximation, the analytical formulae derived from the antenna theory can be used to predict the lateral attenuation from the valve hall.

The attenuation of the noise level is approximately proportional to the inverse of the square of the distance for frequencies up to 1 MHz and becomes proportional to the inverse of the distance for higher frequencies (>10 MHz).

The attenuation of the radio interference levels calculated as a function of the distance is given in Figure 17 for different frequencies.

7.3.3 Reduction of the radio interference due to direct radiation from the valve hall

The electromagnetic screen of the valve hall has proved to be effective for reducing the radiated noise level from the converter valves. Solid metallic sheets, perforated sheets, and wire mesh may be used to achieve the desired shielding. However, due consideration should be given to the construction techniques, availability of materials, and overall cost before the design of the valve hall can be finalized.

Metallic screens having a high conductivity, and preferably also high permeability, in the form of either solid plates or wire mesh, are generally used in the walls and ceiling of the valve hall to provide the electromagnetic shielding. Together with the wire-mesh ground grid embedded in the floor, they form a Faraday cage around the valves. By taking appropriate precautions to ensure good contact between different sections forming this Faraday cage, the radiated

interference can be attenuated by 40 dB to 60 dB. Any discontinuities, gaps or holes in the shielded enclosure will naturally reduce the attenuation.

The connections between the valves and the a.c. and d.c. sections of the outdoor switchyard provide a conductive coupling resulting in a radiation from the busbars and the various elements in the switchyard itself. This radiation may thus become much more important than that from the valve hall and thus the screening of the valve hall may not be sufficient to achieve the requirements on the radiated field strength from the converter station. In such a case also the radiated field strength from the switchyard shall be reduced. To do this at least two ways are possible. The first is to reduce the noise level coming through the valve hall bushings by installing filters. Another is to screen the entire switchyard electromagnetically. If noise reduction within a narrow bandwidth is required, the first method is normally adopted. To make the filters more effective, they may be enclosed with the valve hall bushings in an electromagnetically screened building adjacent to the valve hall.

7.4 Conducted interference along the transmission lines

7.4.1 Description of the mechanism and typical longitudinal profiles

Radio interference currents are transmitted from the converter valves both to the d.c. and to the a.c. lines connected to the converter station. In the case of the a.c. lines, the high-frequency currents are conducted through the capacitive couplings of the converter transformer windings. A grounded shield between windings could be used to reduce this transfer.

The radio interference spectra due to currents injected by converter valves have a shape similar to those generated by corona. An example of noise spectrum, measured near the HVDC line at a short distance from a converter station is shown in Figure 18 and in Figure 19 for an a.c. line. Figure 20 gives the noise spectrum measured in the vicinity of the electrode line, at a distance of 1,5 km from the same converter station operated with thyristor valves and mercury valves.

The radio interference caused by the valve noise currents on the outgoing lines has been found to be dominated by the zero sequence component of the currents. The attenuation of this component is very high compared to that of line-to-line modes and therefore the radio noise level at a given distance from the line decreases rapidly with distance from the converter station. At higher distances, the line-to-line mode components will dominate. As a consequence, the radio interference due to the valves is overridden by corona noise at distances exceeding 5 km to 10 km from the converter station. For a.c. lines, the corresponding distance is somewhat longer. As a guide, an attenuation rate for the longitudinal profile of the radio noise equal to about 4 dB/km can be assumed [13], [14], [44].

Results of measurement of the frequency spectra along a d.c. transmission line at different distances from the converter station are given in Figures 21 and 22. It has to be remembered that in the measurements performed in the vicinity of the first spans, the contribution of the direct radiation from the converter station cannot be disregarded.

For the evaluation of the lateral attenuation of the radio noise from the line, see 8.2 of CISPR/TR 18-1.

7.4.2 Reduction of the interference conducted along the transmission lines

The electromagnetic disturbances due to valve firing, conducted and radiated from the d.c. and a.c. lines connected to a converter station may disturb not only the radio reception but also powerline carrier systems. For these telecommunication systems, especially in the frequency range from some tens to a few hundreds of kilohertz where the level of disturbance may be relatively high, filtering may be necessary.

Band-pass filters made of capacitors and inductors (generally with resistive dampers) shall take into account the stray capacitances and inductances of the bus connections and

equipment. If filtering were necessary even in the frequency range above 1 MHz, simple filters made of a single conductor parallel to the line with a length equal to a quarter of the wavelength to be protected can be used. It has, however, to be noted that these filters allow for the protection of only a limited band of frequency.

7.5 General criteria for stating limits

7.5.1 Overview

In the case of HVDC converting stations, as for the radio interference from transformer stations, the assessment of general criteria for determining limits shall take into account the two propagation ways of the noise:

- direct radiation in the area around the converting station;
- propagation of the noise along the d.c. and a.c. lines starting from the converting station.

NOTE In limited areas close both to the converter station and to outgoing lines (these areas are within one or two kilometres at the most from the border of the converting station), there is a superposition of the two above ways of noise propagation. The effect of this superposition is difficult to be predicted. If it is deemed necessary to cover this aspect, an additional margin could be added to the limit for the radiated field.

7.5.2 Direct radiation

The radiated field strength at a reference distance from the border of the converting station should be limited according to the criteria indicated in Clause 5 of this technical report, which takes into account an acceptable signal to noise ratio (SNR) and the statistical distribution of the noise level. To this purpose, it should be reminded that the radio noise produced by converter stations is not correlated, as corona noise, to the weather conditions. The reference 80 % value can be derived from a statistical distribution where the variability is determined by the different possible conditions of operation of the converter station (functioning as inverter or rectifier, firing and extinction angles, level of the direct voltage, etc.).

In practice, in the very frequent case of an HVDC converting station operating for more than 80 % of the time at conditions close to the nominal conditions, the 80 % radio noise level will coincide with that of nominal operating conditions.

7.5.3 Propagation along the lines

The basic criterion is that the contribution of the radio noise current due to the operation of the converting station in each line, d.c. and a.c., connected to the station, shall not substantially increase the intrinsic noise level of the line beyond a given distance from the station. This distance should be determined considering the type of area crossed by the line (rural areas, residential area, etc.). To keep this increase within 3 dB at the above-mentioned distance, the noise current level arriving in that point from the converting station should be around 10 dB lower than the noise current level of the line.

The noise current value from the converter station at the distance of interest along the line, corresponds to the total noise current value produced either on the a.c. side or on the d.c. side of the station divided by the number of a.c. and d.c. lines, respectively, diminished according to the expected longitudinal attenuation from its injection point to the point of observation at the line. Unless more specific information is available, the longitudinal attenuation factors indicated in 7.4.1 can be taken as a reference.

To determine the 80 % limits of the radio noise current generated by the converter station, the variability of the noise currents of the line (depending on weather conditions) and that of the converter station (depending on the operating conditions; see 7.5.2) shall be taken into account. As the variability of the intrinsic noise of the line is generally much higher than that generated by the station, the limit for the station noise current level can be determined conservatively comparing directly the 80 % values of the two distributions.

Based on the above indications, the 80 % value of the noise current level from the converting station, $I_{80\% \text{-CS}}$, may be put in relationship with the 80 % value of the level of the line, $I_{80\% \text{-L}}$, both expressed in dB, by means of the following formula.

$$I_{80\% \text{-CS}} = I_{80\% \text{-L}} + A + 20 \lg(n) - 10 \quad \text{in dB}(\mu\text{A})$$

where

n is the number of d.c. or a.c. lines;

A is the attenuation along the length of line (in dB) for which an increase of more than 3 dB is accepted.

NOTE To verify that the radio interference level at a given lateral distance from the line complies with the criterion indicated above, the measurements should be performed at a longitudinal distance from the border of the converting station sufficient to avoid the superposition effect mentioned in 7.5 (more than 1 km, e.g. at 2,5 km).

8 Figures

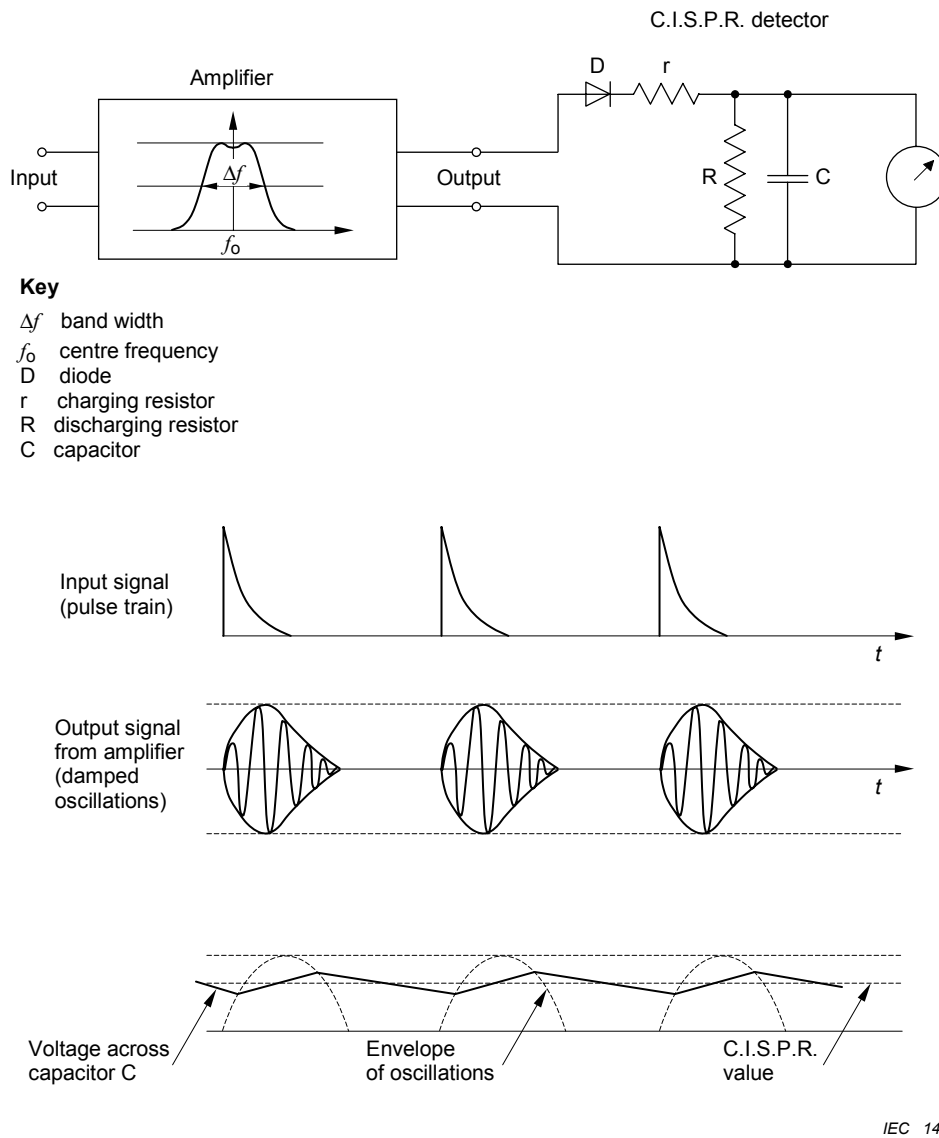
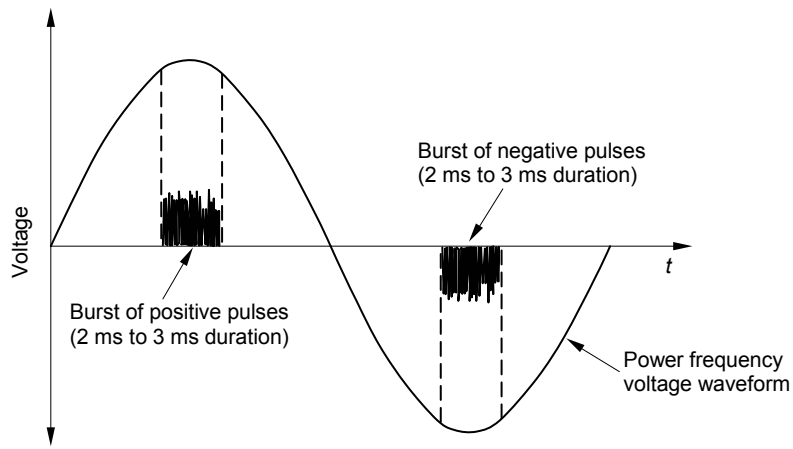
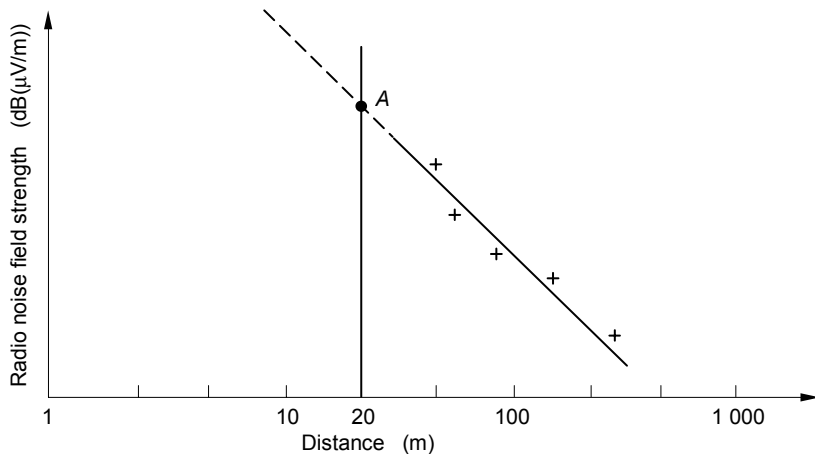

Figure 1 – Transformation of pulses through a CISPR measuring receiver



IEC 1489/10

Figure 2 – Bursts of corona pulses generated by alternating voltage



IEC 1490/10

Figure 3 – Example of extrapolation to determine the radio noise field strength reference level of a power line, here at the direct reference distance of 20 m

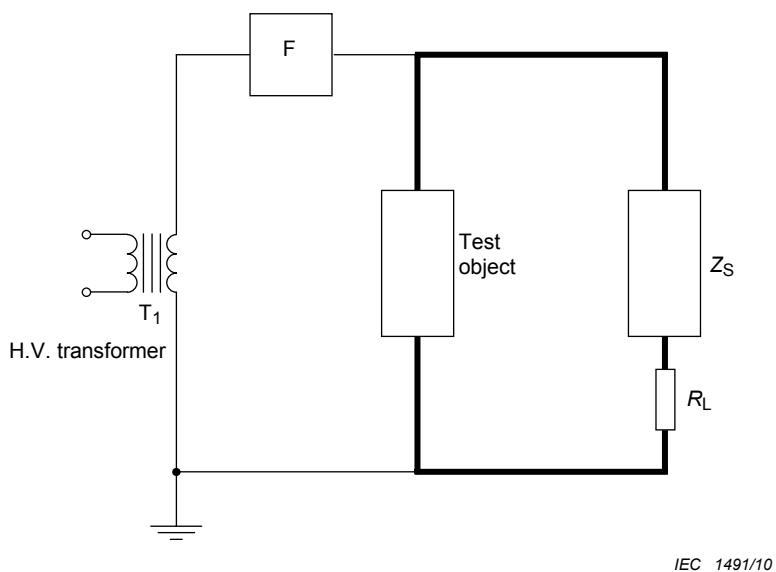
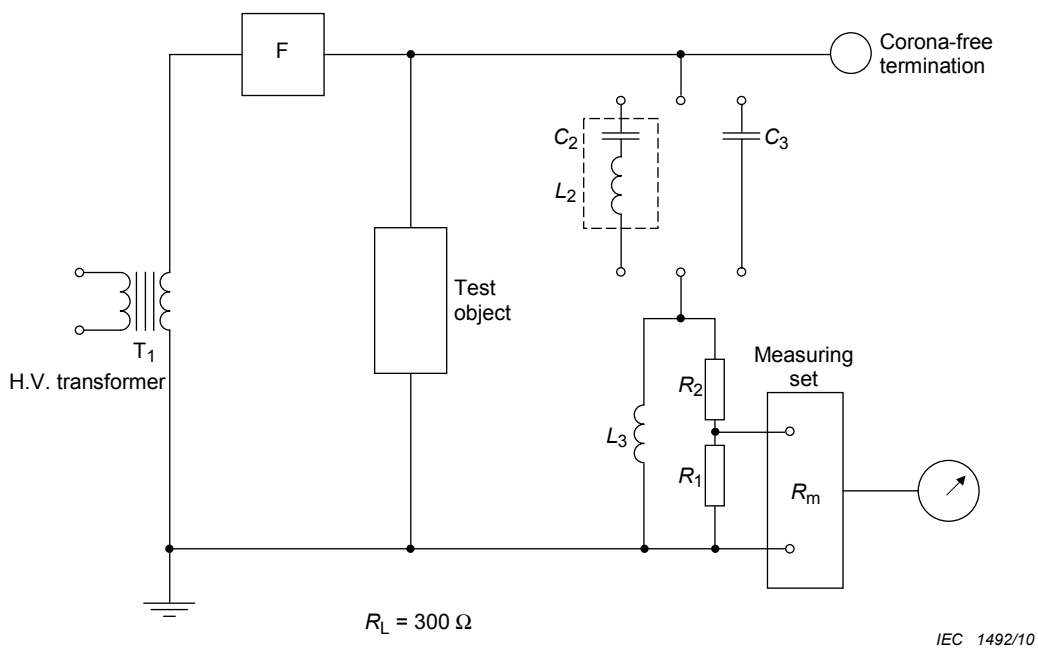

Figure 4 – Basic test circuit



NOTE Filter F may be aperiodic or consist of L_1 in parallel with C_1 .

Figure 5 – Standard test circuit

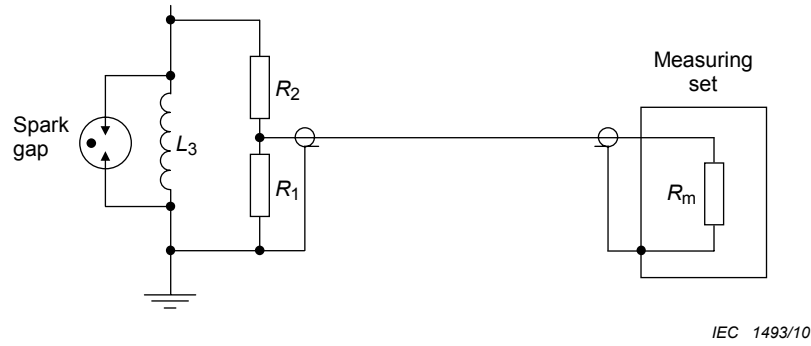

Figure 6 – Connection to the measuring receiver by a coaxial cable

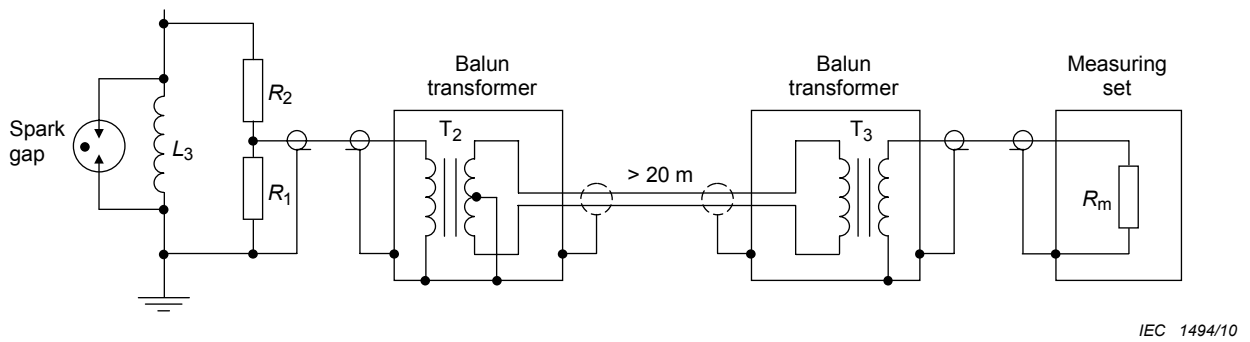

Figure 7 – Connection to the measuring receiver by a balanced cable

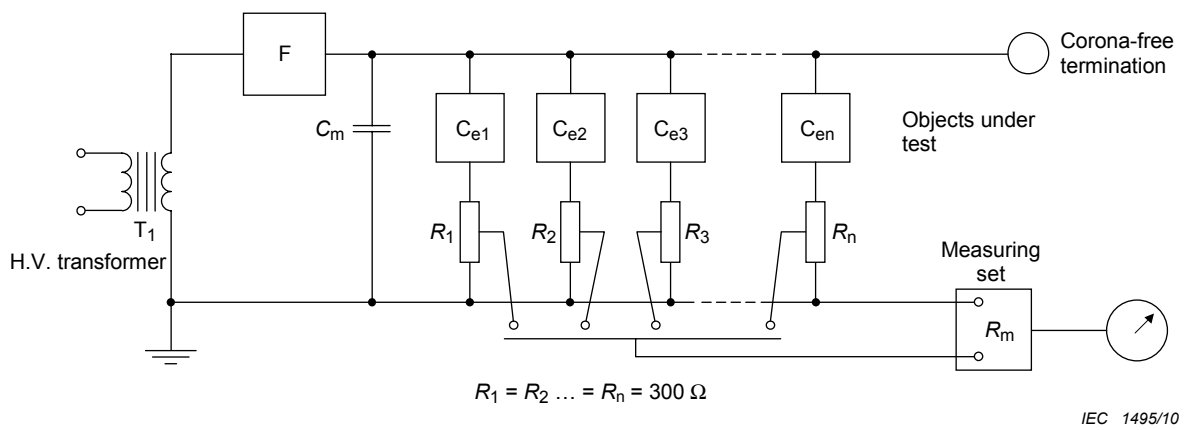

Figure 8 – Special test circuit

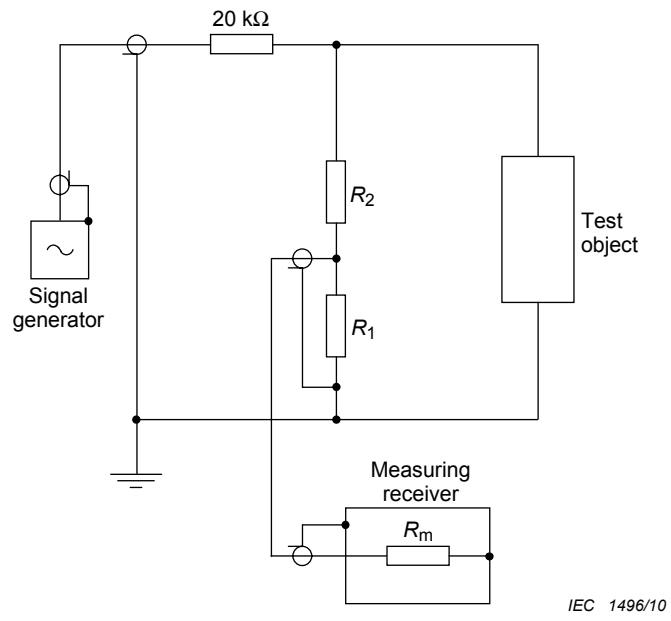
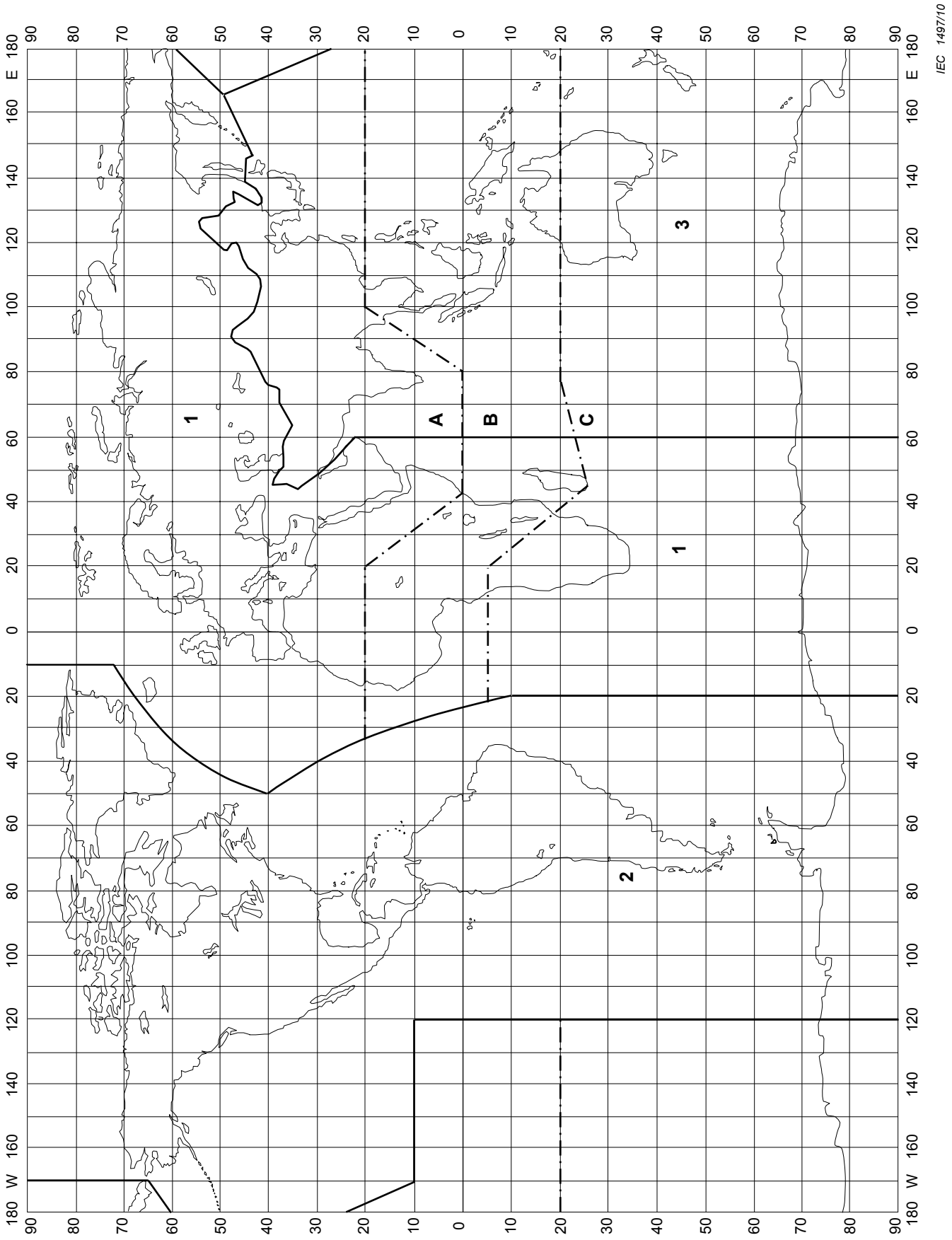

Figure 9 – Arrangement for calibration of the standard test circuit



IEC 1497/10

Figure 10 – Map showing boundaries of zones A, B, and C in regions 1 and 3

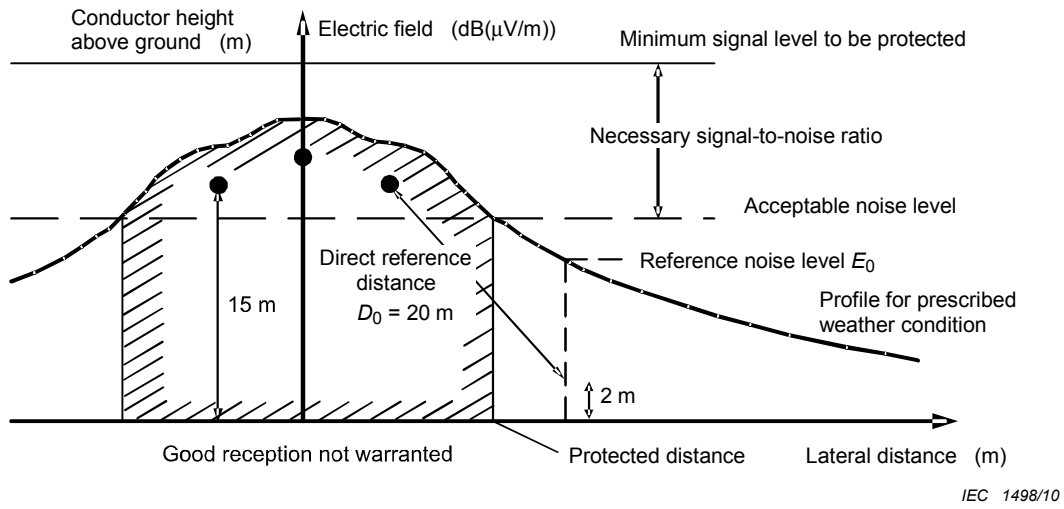

Figure 11a – Situation for a power transmission line with a conductor height above ground up to 15 m

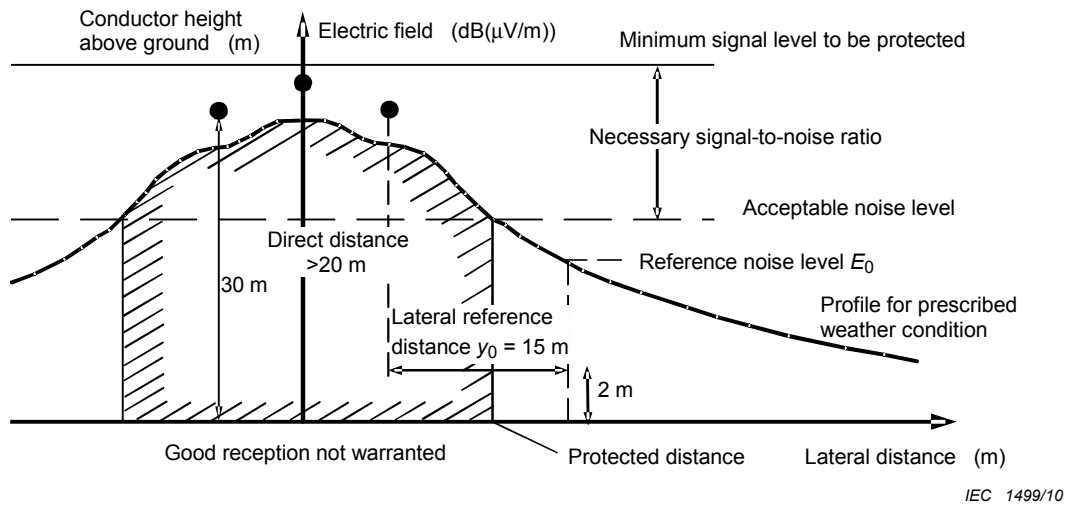

Figure 11b – Situation for a power transmission line with a conductor height above ground greater than 15 m

Figure 11 – Illustration of the four basic parameters for a power transmission line

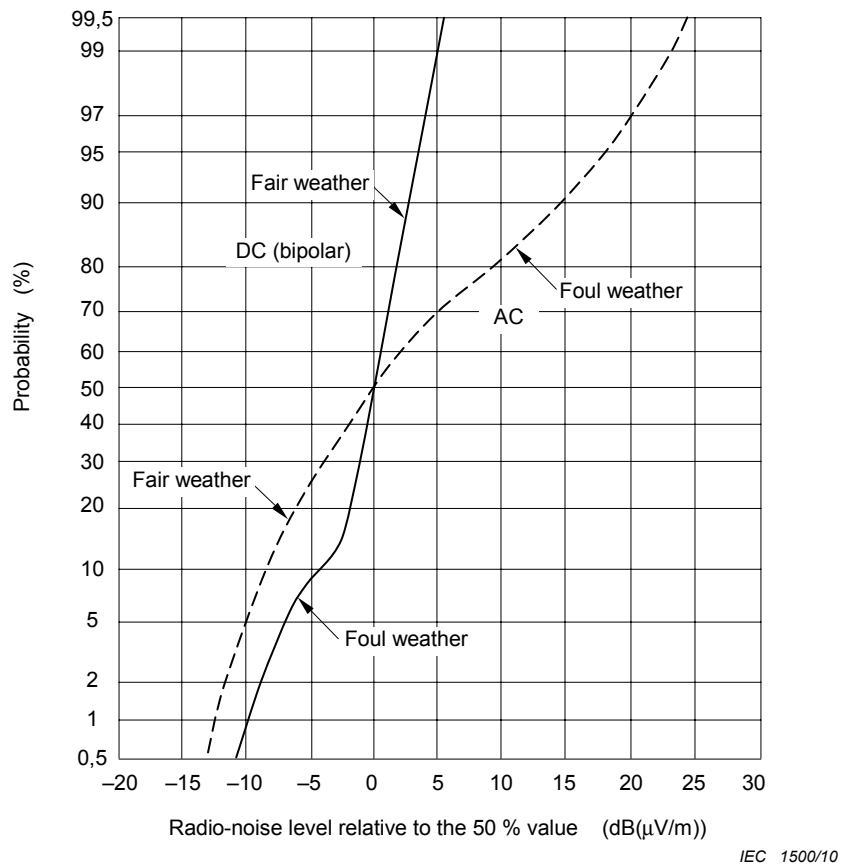

Figure 12 – Example of typical statistical yearly "all-weather" distributions of the radio-noise levels of a bipolar direct current line (-----) and for an alternating current line in a moderate climate (- - -)

The 80 % radio noise level corresponds to fair weather for the direct current line and to foul weather for the alternating current line.

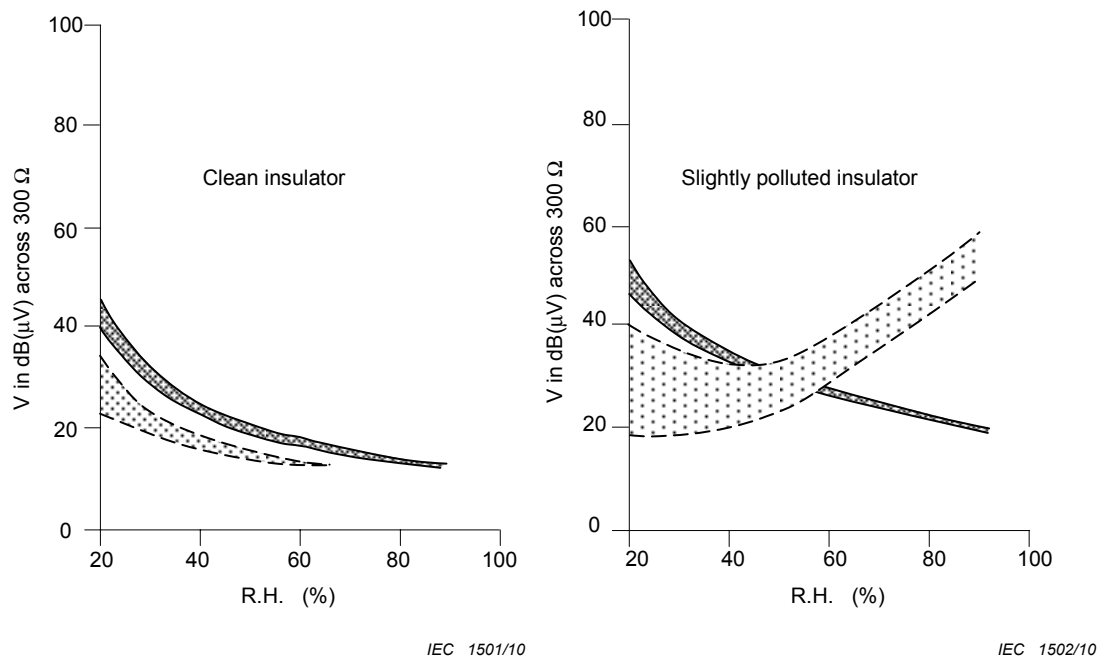

Figure 13 – Example of radio noise voltage level V, as a function of the relative air humidity R.H., in clean conditions and slightly polluted conditions, of a standard insulator (—) and a particular type of "low noise" insulator (- - -)

Both insulators are glass cap-and-pin insulators of the same class (U120 BS as in IEC 60305 [8]). For each insulator type one single unit was tested at a voltage of 14 kV.

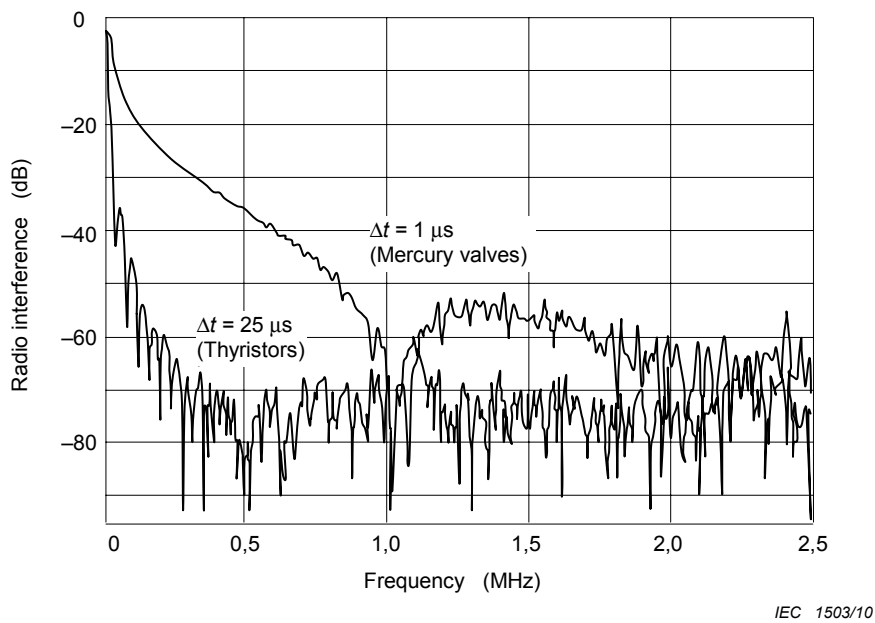

Figure 14 – Example of frequency spectra of pulses with different rise times, simulating commutation phenomena in mercury valves and in thyristor valves

(see reference [39])

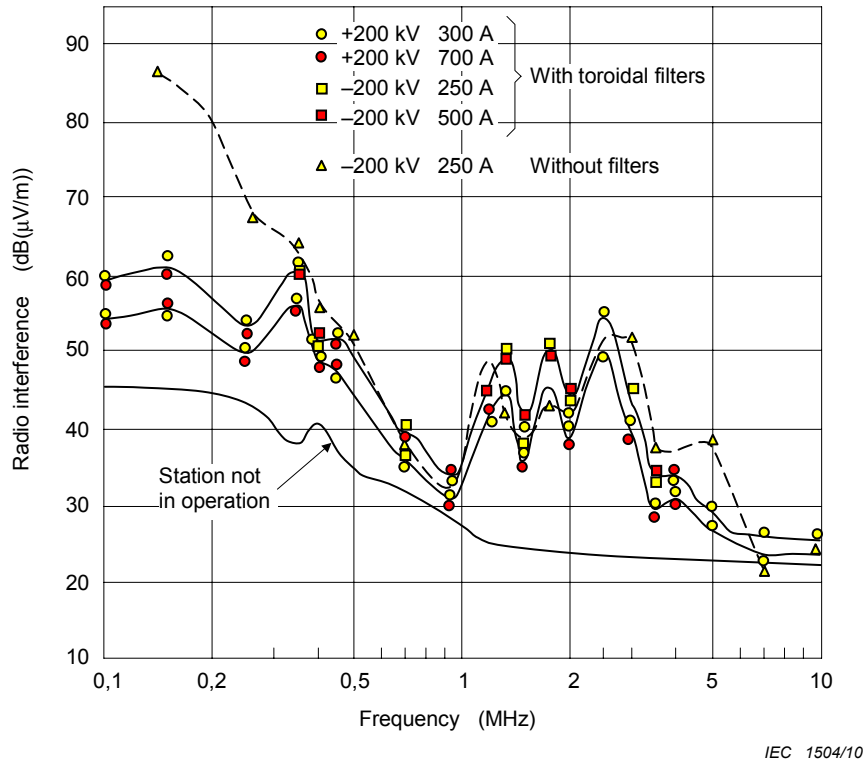

Figure 15 – Example of frequency spectra of the radio interference recorded outside the hall of a mercury arc valve converter station with and without toroidal filters
(see reference [39])

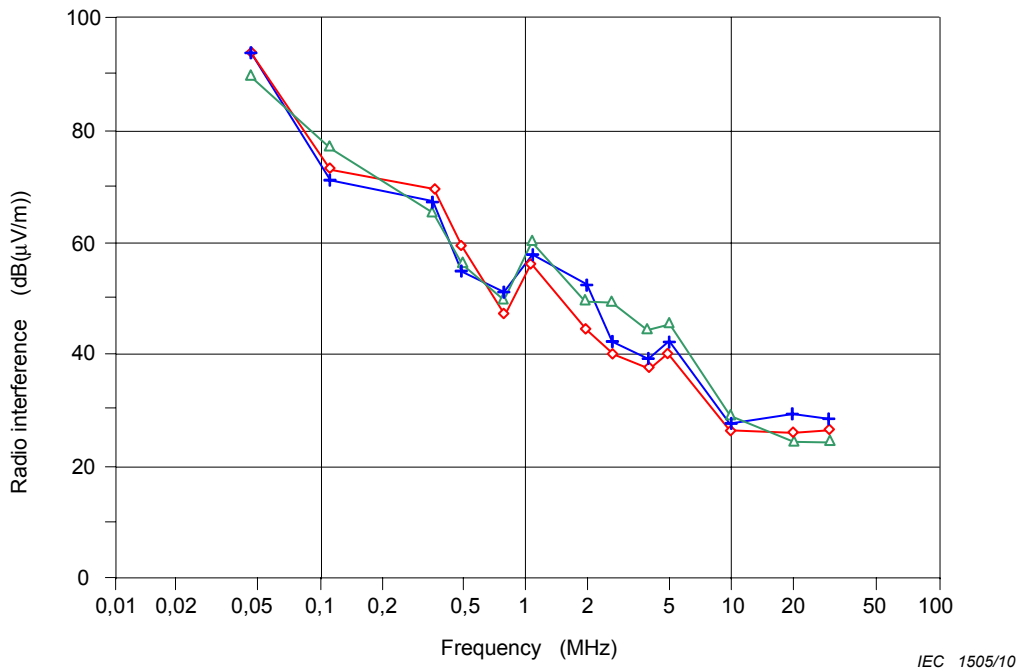

Figure 16 – Example of frequency spectra of the radio interference recorded outside the hall of a thyristor valve converter station for different operating conditions

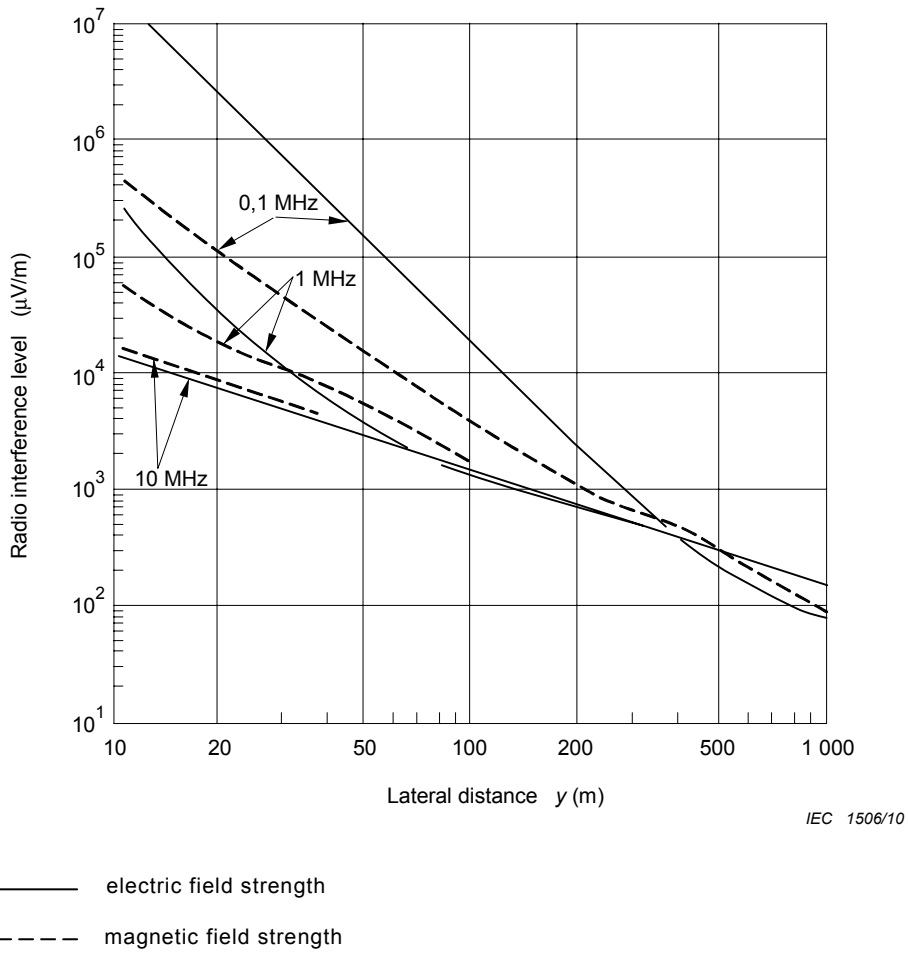

Figure 17 – Attenuation of the field strength as a function of the distance on a horizontal plane, for different frequencies

(Calculated levels for free wave propagation of a radiation caused by a vertical electrical dipole; see reference [36])

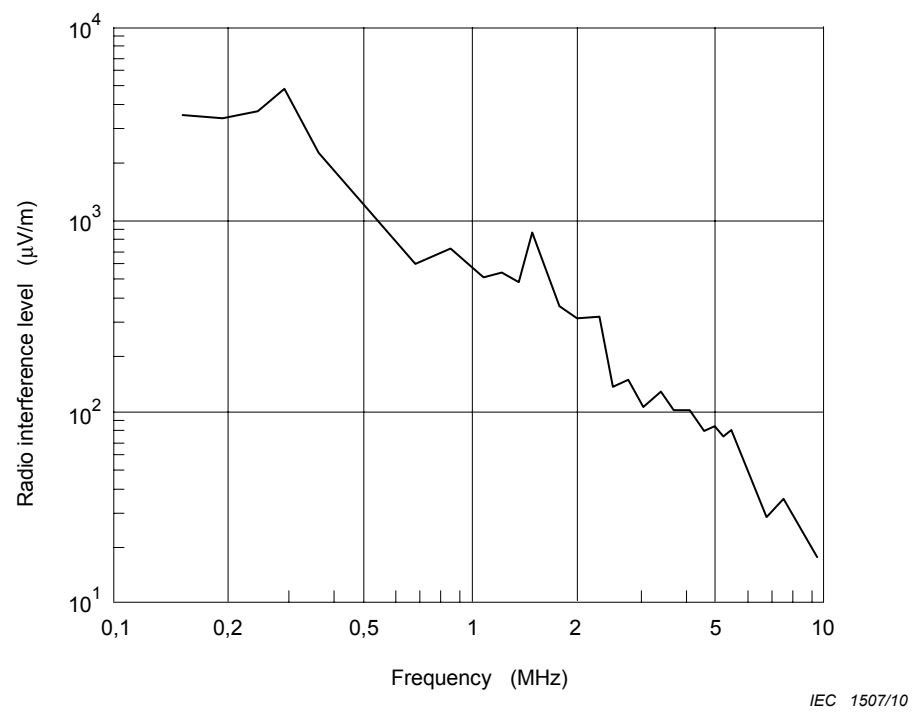
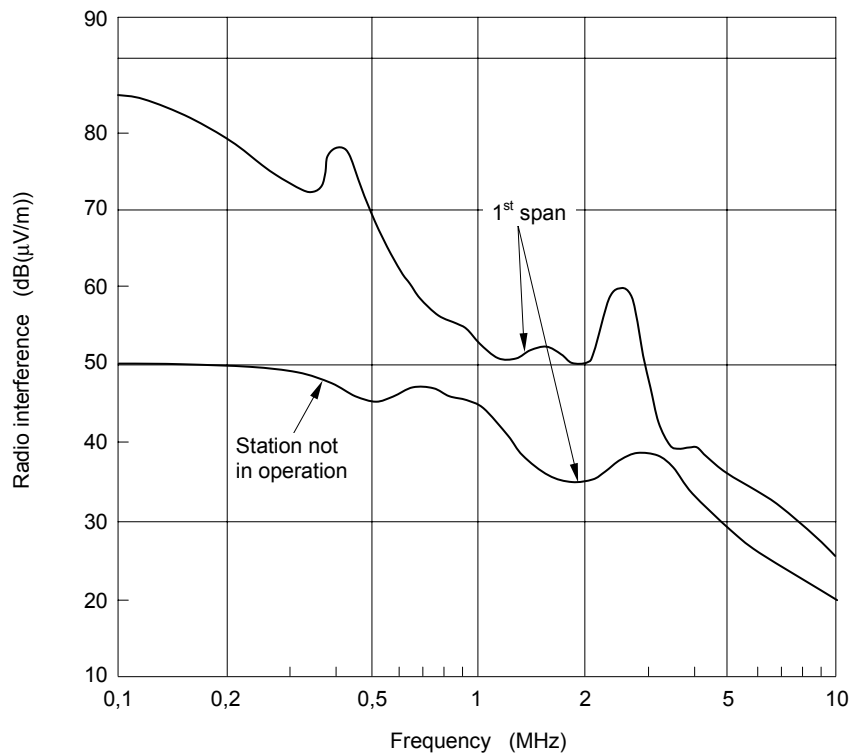

Figure 18 – Example of frequency spectrum of the radio interference in the vicinity of a d.c. line (30 m) at a short distance from the converter station

(see reference [36])



IEC 1508/10

Figure 19 – Example of frequency spectrum of the radio interference in the vicinity of an a.c. line (20 m) at a short distance from the converter station

(see reference [39])

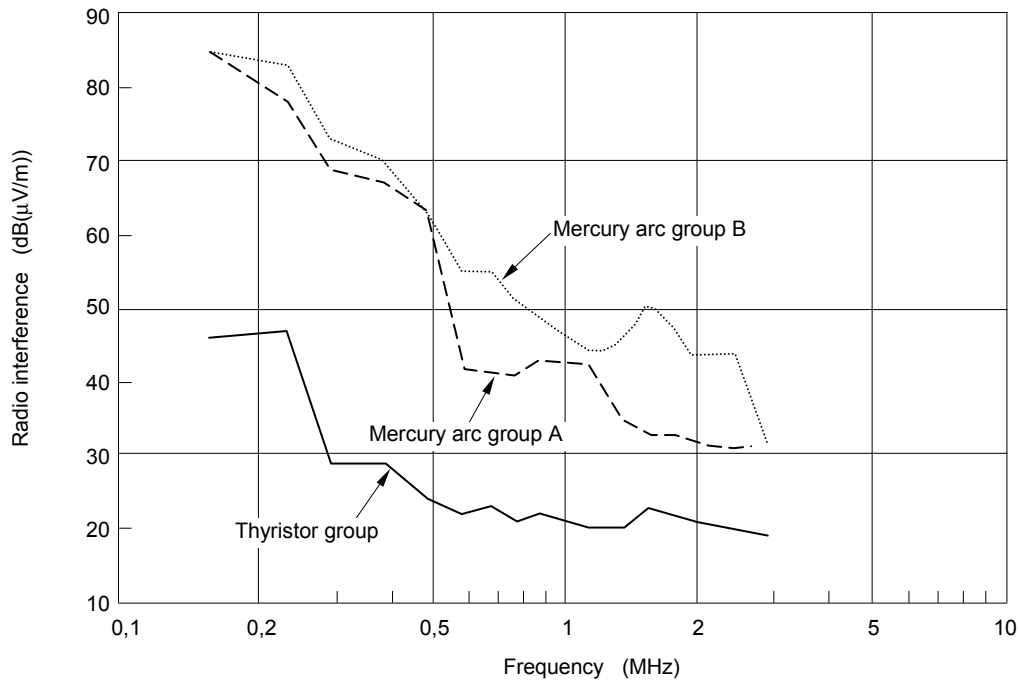

IEC 1509/10

Figure 20 – Frequency spectra of radio interference at 20 m from the electrode line at 1,5 km from the Gotland HVDC link in Sweden with mercury arc groups or thyristor groups in operation

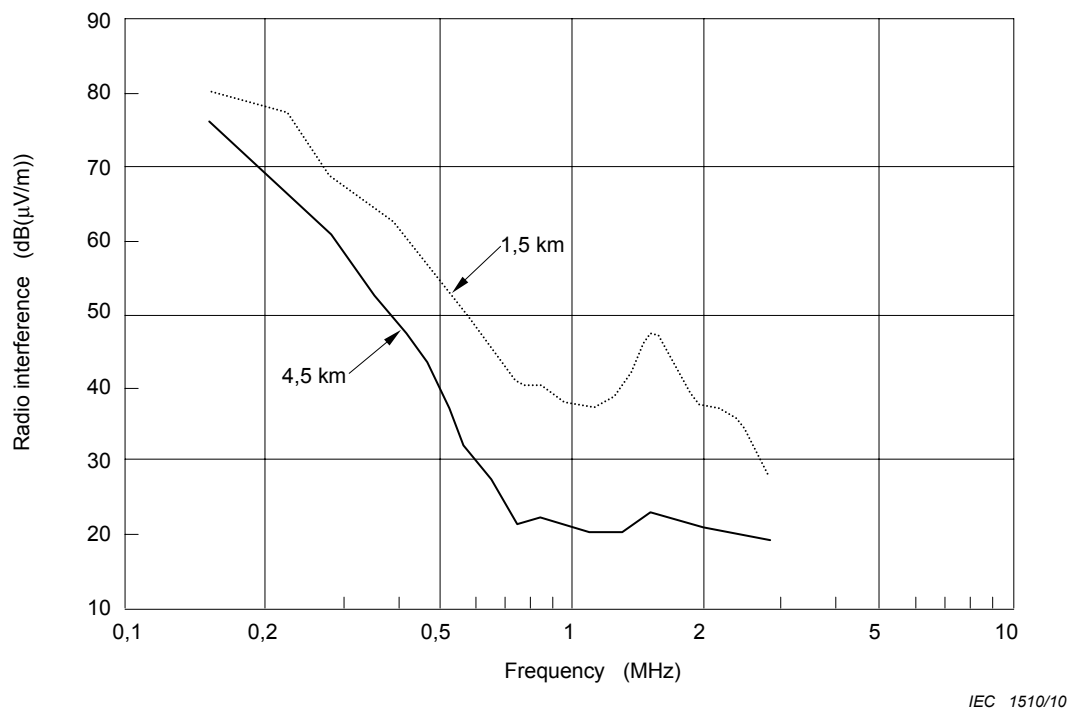

Figure 21 – Frequency spectra of radio interference at 20 m from the electrode line at 1,5 km and 4,5 km from the Gotland HVDC link in Sweden with mercury arc groups in operation

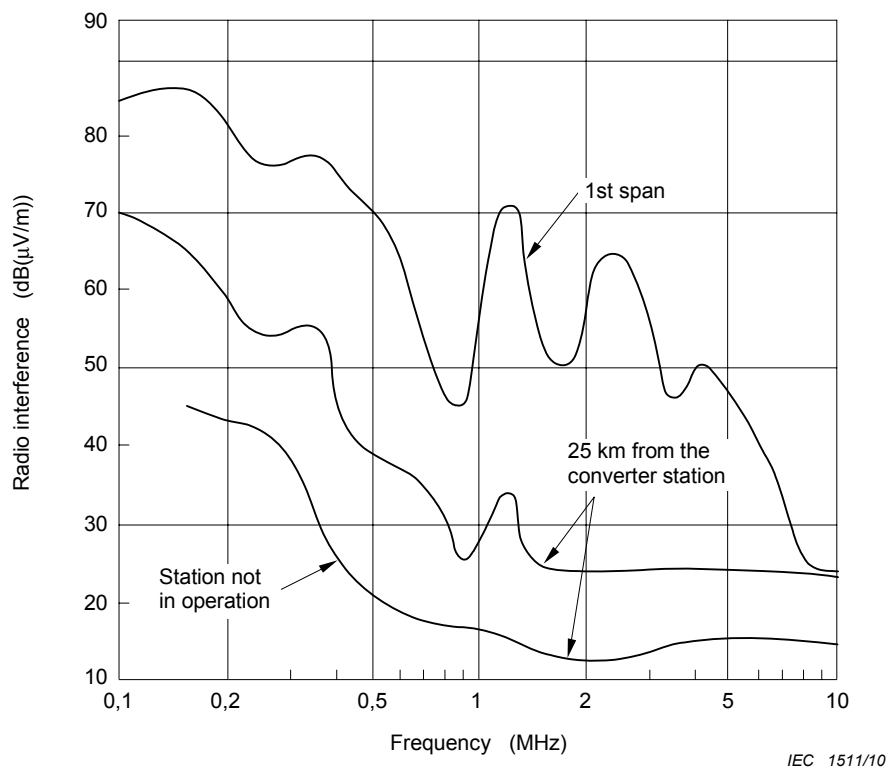

Figure 22 – Frequency spectra of the radio interference recorded along a 200 kV d.c. line, at 20 m from the conductor, at different distances from the converter station

(see reference [39])

Annex A (informative)

Radio interference measuring apparatus differing from the CISPR basic standard instruments

In addition to the instruments specified in CISPR 16-1-1, which are the basic reference instruments for determining compliance with CISPR limits in the frequency range 0,15 MHz to 300 MHz, there are instruments of other types used for radio noise measurements on power lines and high-voltage equipment.

In the United States and Canada, ANSI (American National Standards Institute) standard instruments which have quasi-peak detectors with a charge time constant of 1 ms and a discharge time constant of 600 ms have been generally used below 30 MHz. Above 30 MHz the CISPR and ANSI time constants are practically the same. At a given frequency below 30 MHz the ANSI meter usually reads 1 dB or 2 dB higher than the CISPR measuring receiver when measuring corona noise. New ANSI standards under consideration incorporate the CISPR specifications for the quasi-peak detectors.

Instruments with detectors other than quasi-peak which include r.m.s., average and peak detectors are specified in CISPR 16-1-1. These instruments should be used for standard measurements only when conversion to quasi-peak values is possible. Although CISPR 16-1-1 gives the conversions to quasi-peak values for periodically repeated pulses, these conversions do not apply to corona pulses which occur in bursts (see 4.1.1).

Annex B

(normative)

List of additional information to be included in the report on the results of measurements on operational lines

When the results of measurements are reported, the following additional information should be included:

- a) Conductor surface voltage gradient – r.m.s. value for system voltage at time of measurements. State, in the case of bundles, if gradient is average or maximum.
- b) Atmospheric conditions at measurement sites: temperature, pressure (altitude), humidity, wind speed, etc.
- c) Pollution of conductors, insulators and fittings. State if "light", "moderate" or "severe" pollution and, if possible, the type of pollution, for example, cement or saline and the resistivity of the equivalent saline mist.
- d) Type of insulator – if radio noise measurements, according to 4.2, have been made on a complete insulator set of this type, the information should be included.
- e) Conductor configuration including:
 - i) presence or not of earth conductor;
 - ii) number of conductors per phase and relative disposition;
 - iii) nature of conductor;
 - iv) height of conductors above ground at measurement site.
- f) Age of line.
- g) Line support – metal tower or wood or concrete pole.
- h) Distance from nearest substation, transposition and angle structure and the presence or not of line traps for carrier communication equipment.
- i) Distance from other lines or sources of interference which may affect the measurements.
- j) Whether the results are from a single measurement or from a statistical assessment. Data from a statistical assessment may conveniently be presented in statistical form using cumulative probability paper. Results may be summarized by quoting the noise levels exceeded for 5 %, 20 %, 50 %, 80 % and 95 % of the time.
- k) The period over which the measurements have been made. For a full assessment of the radio noise performance of a high voltage line, only measurements made over a sufficiently long period may be considered as significant.
- l) Resistivity of the soil, if known.
- m) The line loading (where this may be important).

Annex C (informative)

Minimum broadcast signal levels to be protected – ITU recommendations

For the l.f. and m.f. bands the ITU has established, for three climatic zones (A, B and C) the minimum field strength necessary to overcome natural noise (atmospheric noise, cosmic noise, etc.) [22]. These levels, which have been determined by adding 40 dB to the value of natural noise distribution exceeded for 10 % of the time, are given in Table C.1:

Table C.1 – Minimum field strength

	Zone		
	A	B	C
Frequency MHz	Field strength dB(μV/m)		
0,15	73	83	76
0,28	70,5	80,5	73,5
0,5	65	75	68
1,0	60	70	63
1,6	57	67	60

For broadcast planning purposes, the ITU has also recommended nominal usable field strengths. These recommendations, including the footnotes, are reproduced here for the 0,5 MHz to 1,7 MHz and 0,15 MHz to 0,28 MHz bands. The exact values of upper and lower limits of the various frequency bands, for different regions of the world, can be found in [21].

The nominal usable field strength values are shown in Table C.2 below in dB(μV/m).

Table C.2 – Nominal usable field strength

	Zone A	Zone B	Zone C
A. Medium frequency (0,5 MHz to 1,7 MHz)			
Daytime ground-wave service	63	73	66
Night ground-wave service ^a			
– rural areas ^b	71	81	74
– urban areas	77	87	80
Low-power channels	77	87	80
B. Low frequency (0,15 MHz to 0,28 MHz) ^c	77	87	80
^a Where the transmitter power is sufficiently high for the ground-wave service area to be limited by fading due to the sky-wave transmitter, a nominal usable field strength greater than the value given in the table may be chosen. It should not, however, be greater than the ground-wave field strength at the beginning of the fading zone. The fading zone may be defined by taking the protection ratio between the ground-wave and the sky-wave to be equal to the internal protection ratio applicable to a synchronized network, that is 8 dB. ^b Some delegations consider a nominal usable field strength of 65 dB(μV/m) to be suitable for rural areas in their countries. ^c Certain delegations consider a value of nominal usable field strength of the order of 73 dB(μV/m) to be appropriate in non-tropical rural areas.			

Annex D (informative)

Minimum broadcast signals to be protected – North American standards

In North America, the signal levels at the edge of the service area of a broadcasting station, according to NARBA and other standards [23], [24], [25] are as described in the Table D.1 below.

Table D.1 – Signal levels at the edge of the service area in North America

Service	Frequency MHz	Signal levels dB(μ V/m)
AM radio	0,5 to 1,7 Some "class A" stations	54 40
VHF television (channel 2 to 6)	54 to 88	4
VHF television (channel 7 to13)	174 to 216	56

Annex E (informative)

Required signal-to-noise ratios for satisfactory reception

AM sound radio broadcasting

Although no exact recommendations concerning acceptable signal-to-noise ratios have been devised for interference from power lines, a number of tests have been conducted throughout the world. These are summarized in reference [25]. In these tests, the noise was measured with either a CISPR measuring receiver or a meter specifying ANSI Specification C63.2-1969 [9]. For measurement of the signal, some investigators used the quasi-peak detector and others used the average detector.

Table E.1 shows all the data, corrected to represent signals measured with an average detector and noise measured with the quasi-peak detector of a CISPR measuring receiver. Table E.2 defines the codes for quality of reception used in Table E.1. Average rather than quasi-peak measurement of the signal level seems logical since signal levels, as defined by international bodies such as CCIR and NARBA, are average or r.m.s. values of the modulated signal.

For the development of limits, any of the ratios in Table E.1 could be used. It is not possible at present to state which is the most accurate. As a guide, the last column of Table E.1 shows the mean of all the values for each quality of reception.

Television broadcasting

Some signal-to-noise ratio tests have been conducted for power line noise in the v.h.f. television bands. The results indicate that a 40 dB ratio, with the signal measured by an average detector and the noise measured by a CISPR measuring receiver, with a quasi-peak detector, may be satisfactory. However, this subject is still under consideration.

**Table E.1 – Summary of signal-to-noise ratios for corona from a.c. lines
(Signal measured with average detector, noise measured with quasi-peak detector)**

Canadian Voluntary Standard		IEEE Radio Noise Design Guide		Lippert Pakala <i>et al.</i>		Taylor <i>et al.</i>		Gehrig <i>et al.</i>		Nigol		CIGRÉ		Hirsch		De Michelis and Rosa		Mean
1	2	3	4	5	6	7	8	9	10	11	12	13	14	15	16	17	18	
Code	Ratio dB	Code	Ratio dB	Code	Ratio dB	Code	Ratio dB	Code	Ratio dB	Code	Ratio dB	Code	Ratio dB	Code	Ratio dB	Code	Ratio dB	
A1	39	–	–	–	–	0	41	–	–	–	–	–	–	–	–	–	–	40
A2	31	A5	31	A	31	1	35	–	31	5	–	5	30	1	3'	0	36	32
B	26	B4	26	B	25	2	29	–	26	4	25	4	24	2	20	1	30	26
C	21	C3	21	C	21	3	23	–	21	3	21	3	18	3	14	2	24	20
D	15	D2	15	D	15	4	18	–	16	2	15	2	12	4	8	3	17	15
E	9	E1	4	E	7	5	12	–	10	1	–	1	6	5	–	4	10	8
–	–	F0	–	F	–	6	6	–	–	0	–	0	0	–	–	5	2	3

The description of the codes shown in Table E.1, which eventually define the quality of reception or degree of annoyance, as used by the various investigators are summarized in Table E.2 below.

Table E.2 – Quality of radio reception or degree of annoyance due to RFI

Column in Table E.1	Description of the codes used in Table E.1
1	Canadian Voluntary Standard
	A1 Entirely satisfactory for classical music A2 Satisfactory for general listening B Background noise reasonably unobtrusive C Background noise evident D Background noise very evident E Difficult to understand
2	IEEE Radio Noise Design Guide
	A5 Entirely satisfactory B4 Very good, background unobtrusive C3 Fairly satisfactory, background plainly evident D2 Background very evident, but speech easily understood E1 Speech understandable only with severe concentration
3	Lippert, Pakala, Bartlett, Fahrnkof
	A Entirely satisfactory B Very good C Fairly satisfactory D Speech easily understood E Speech understandable F Speech unintelligible
4	Taylor et al.
	0 Excellent 1 Entirely satisfactory 2 Very good 3 Fairly satisfactory 4 Speech easily understood 5 Speech understandable 6 Speech unintelligible

Table E.2 (continued)

Column in Table E.1	Description of the codes used in Table E.1
5	<p>Gehrig, Peterson, Clark, Rednour</p> <ul style="list-style-type: none"> Background not detectable Background detectable Background evident Background objectionable Difficult to understand Unintelligible
6	<p>Nigol (Burrill's Code)</p> <ul style="list-style-type: none"> 5 Entirely satisfactory 4 Very good, background unobtrusive 3 Good, background evident 2 Program easily understood, background very evident 1 Program badly distorted, background very evident 0 Program unintelligible
7	<p>CIGRÉ</p> <ul style="list-style-type: none"> 5 Interference not audible 4 Interference just perceptible 3 Interference audible, but speech perfectly received 2 Unacceptable for music, but speech intelligible 1 Speech understandable only with several concentration 0 Spoken word unintelligible; noise swamps speech totally
8	<p>Hirsch</p> <ul style="list-style-type: none"> 1 Very good reception, no disturbance detectable 2 Good reception, disturbance without severe nuisance 3 Satisfactory reception, disturbance evident 4 Sufficient reception, distorted with very evident noise 5 Insufficient reception, program unintelligible
9	<p>De Michelis and Rosa</p> <ul style="list-style-type: none"> 0 No interference. No disturbance perceived 1 Barely perceptible. Disturbance audible during conversation in a low voice, but not during conversation in a normal voice 2 Perceptible. Disturbance audible in any case but not particularly irritating 3 Somewhat objectionable. Disturbance audible even during musical broadcast 4 Definitely objectionable. Irritating but perfectly intelligible 5 Intolerable. Extremely irritating disturbance with reduced intelligibility

Annex F (informative)

Derivation of the formula for the protected distance

The formula used in the examples in 5.5.1.3 and 5.5.1.4 is derived as follows:

The acceptable noise level at the protected distance is:

$$N_P = S_P - R_P$$

where

N_P is the acceptable noise level at D_P , in dB(μ V/m);

S_P is the protected wanted radio signal level, in dB(μ V/m);

R_P is the required signal-to-noise ratio (SNR), in dB;

D_P is the protected distance, in metres (m).

But using the attenuation formula given in 5.3.5.1:

$$N_P = E_0 - K \lg \frac{D_P}{20}$$

where

E_0 is the noise level at the reference distance, in dB(μ V/m); and

K has a value of 36 for l.f. band, and 33 for m.f. band.

$$S_P - R_P = E_0 - K \lg \frac{D_P}{20}$$

Therefore

$$D_P = 10^{\left(\frac{E_0 + R_P - S_P}{K} \right)}$$

Bibliography

- [1] CISPR 16 (all parts), *Specification for radio disturbance and immunity measuring apparatus and methods*
- [2] CISPR 16-1-2, *Specification for radio disturbance and immunity measuring apparatus and methods – Part 1-2: Radio disturbance and immunity measuring apparatus – Ancillary equipment – Conducted disturbances*
- [3] IEC 60437:1997, *Radio interference tests on high-voltage insulators*
- [4] ANSI/IEEE Standard 430 (1986), *IEEE Standard Procedures for the Measurement of Radio Noise from Overhead Power Lines and Substations -Description*
- [5] IEEE Standard 473 (1985), *IEEE Recommended Practice for an Electromagnetic Site Survey (10 kHz to 10 GHz)*
- [6] C.R. Bond, W.E. Pakala, R.E. Graham, J.E. O'Heill: *Experimental Comparisons of Radio Influence Fields from Short and Long Transmission Lines*, IEEE Transactions on Power Apparatus and Systems, vol. 82, April 1963, pp. 175-185.
- [7] NEMA Publication 107 (1964), *Methods of Measurement for Radio Influence Voltage of High Voltage Apparatus*
- [8] IEC 60305, *Insulators for overhead lines with a nominal voltage above 1 000 V – Ceramic or glass insulator units for a.c. systems – Characteristics of insulator units of the cap and pin type*
- [9] ANSI Specification C63.2 (1969), *American National Standard for Electromagnetic Noise and Field Strength Instrumentation, 10 Hz to 40 GHz-Specifications -Description*
- [10] F.W. Hirsch, E. Schafer: *Progress Report on the HVDC Test Line of the 400 kV - Forschungsgemeinschaft: Corona Losses and Radio Interference*, IEEE Transactions on Power Apparatus and Systems, vol. 88, pp. 1061-1069, July 1969.
- [11] E.H. Gehrig, A.C. Peterson, C.F. Clark, T.C. Redmour: *BPA's 1100 kV DC Test Project, Part II, Radio Interference and Corona Loss*, IEEE Transactions on Power Apparatus and Systems, vol. 86, March 1967.
- [12] *Transmission Line Reference Book HV DC TO + 600 kV*, published by Electric Power Research Institute, 3412 Hillview Avenue, Palo Alto, CA 94304.
- [13] *Interference Produced by Corona Effect of Electric Systems (Description of Phenomena, Practical Guide for Calculation)*, International Conference on Large High Voltage Electric Systems (CIGRÉ), Paris 1974.
- [14] *Transmission line reference books, 340 kV and above*, Electric Power Research Institute, 1975.
- [15] D. Riviere, R. Parraud, C. Gary, M. Moreau, D. Khoutova, J. Vokalek: *The Influence of Ambient Conditions on the Interference Level of Insulator Strings*, CIGRÉ Report 36.04, 1972
- [16] P.D. Bernardelli, R. Cortina, M. Sforzini: *Laboratory Investigation on the Radio Interference Performance of Insulators in Different Ambient Conditions*, IEEE Transactions on Power Apparatus and Systems. vol. PAS-92, January/February 1973, pp. 14-24.

- [17] *Radio Noise Design Guide for High Voltage Transmission Lines*, IEEE Committee Report, IEEE Transactions on Power Apparatus and Systems, vol. PAS-90, March/April 1971, pp. 833-842.
- [18] Y. Sawada, T. Sugimoto, M. Ushirozawa: *Radio Noise and Corona Loss of 500 kV Power Transmission Line and Substation*, CRIEPI Report No. 7 (Japanese), Central Research Institute of Electric Power Industry (CRIEPI), Japan, June 1970.
- [19] IEEE Tutorial Course (1976): *The Location, Correction and Prevention of ri and tvi Sources from Overhead Power Lines*.
- [20] CCIR XIV Plenary Assembly, Kyoto 1978, vol. VIII Recommendation 560, vol. XI Recommendation 417-2, 418-3.
- [21] International Telecommunication Union: *Radio Regulations*, 1982.
- [22] International Telecommunication Union: *Final Acts of the Regional Administrative L.F./M.F. Broadcasting Conference*, Geneva, 1975.
- [23] North American Regional Broadcasting Agreement, 1950, Annex 2, Appendix B.
- [24] *FCC Rules and Regulations*, United States Government, Sections 73.683, 73.684.
- [25] Department of Communications, Government of Canada, Broadcast Procedure No. 5: *Protection and Coverage Rules for V.H.F. Television Allocations in Canada*.
- [26] CISPR Recommendation 46/1: *Significance of CISPR Limits*, CISPR Publication 16.
- [27] *Influence on the dc Corona Noise on Signal Reception in Comparison with ac Corona Noise*, Central Research Institute of Electric Power Industry (CRIEPI), Japan, Report No. 72510, July 1972.
- [28] *Bipolar HVDC Transmission System Study Between ± 600 kV and ± 1 200 kV – Corona Studies, Phase II*. Electric Power Research Institute, Final Report No. EL/2794 on Project 430-2, December 1982.
- [29] R. Parraud, D. Rivière: *Role played by insulators in the interference level of overhead lines: critical conditions*. CIGRE Paper 36.05; 1974.
- [30] D. Rivière, R. Parraud, C.E. Ricketts, I.G. McLean: *Radiointerference: insulators*. CIGRE paper 36.07, 1976.
- [31] C. Gary, D. Rivière, R. Parraud: *Radiointerference produced by insulator strings: limit values and string design*. CIGRE Symposium 1981 – Report 232.09
- [32] Y. Sawada, M. Fukushima, M. Yasui, I. Kimoto, K. Naito: *A Laboratory Study on RI, TVI and AN of Insulator Strings Under Contaminated Conditions*, IEEE Transactions on Power Apparatus and Systems, Vol. PAS-93, No. 2, March/April 1974, pp. 712-719.
- [33] T. Fujimora, K. Naito, Y. Hasegawa, R. Matsuoka, Y. Nakashima: *Studies on Corona Performance of Insulator Assemblies for UHV Transmission Lines*. IEEE Transactions on Power Apparatus and Systems, Vol. PAS-98, No. 3, May/June 1979, pp. 860-870.
- [34] P. Sarma Maruvada: *Electromagnetic Interference from HVDC Converter Stations*. E.E.C.P.S. - Capri - May '89

- [35] P. Sarma Maruvada, T. Gisling: *A Method of calculating the Radio Interference from HVDC Converter Stations*. IEEE Transactions, Vol. PAS-92, pp. 1009-1018, May/June 1973
- [36] S. A. Annestrand: *Radio Interference from HVDC Converter Stations*. IEEE Transactions, Vol. PAS-91, pp. 874-882, May/June 1972
- [37] *Radio Interference from HVDC Converter Stations: Modelling and Characterization*. EPRI Report EL-4956, Dec. 1986
- [38] P. Sarma Maruvada, R. Malewski, P. S. Wong: *Measurement of the electromagnetic environment of HVDC Converter Stations*. IEEE Summer Meeting 1988, Portland, 88 SM 582-9
- [39] R. Cortina, F. Demichelis, P. Nicolini, F. Rosa, A. Giorgi: *HVDC Link Between Sardinia, Corsica and the Italian Mainland (S.A.C.O.I.). Interference with Telecommunication*. E.E.C.P.S. - Capri, May '89
- [40] R. D. Dallaire, P. Sarma Maruvada: *Evaluation of the Effectiveness of Shielding and Filtering of HVDC Converter Station*. IEEE Summer Meeting 1988, 88 SM 567-0
- [41] R. M. Morris et alii: *The Corona and Radio-interference Performance of the Nelson River HVDC Transmission Lines*. IEEE Vol. PAS-98 No. 6, Nov./Dec. 1979, pp. 1924 to 1936
- [42] *Radio interference from HVDC Converter Stations*. EPRI Report EL-3712, Oct. 1984
- [43] S. A. Sebo, R. V. De Vore, R. Caldecott, J. L. He: *Design and RF Operation of Large Scale Model of Dickinson ± 400 kV HVDC Converter Station*. IEEE Transactions, Vol. PAS-104, pp. 1930-1936, July 1985
- [44] C. Gary, M. Moreau: *L'effet de couronne en tension alternative*. (Book) Collection de la Direction des Etudes et Recherches d'Electricité de France, Eyrolles 1976.
-

INTERNATIONAL
ELECTROTECHNICAL
COMMISSION

3, rue de Varembé
PO Box 131
CH-1211 Geneva 20
Switzerland

Tel: + 41 22 919 02 11
Fax: + 41 22 919 03 00
info@iec.ch
www.iec.ch